

SENSAPHONE[®]

REMOTE MONITORING SYSTEMS

Sensaphone 2800

User's Manual



SENSAPHONE®

2800

Environmental Monitoring System

User's Manual

Version 1.2

Every effort has been made to ensure that the information in this document is complete, accurate and up-to-date. Sensaphone assumes no responsibility for the results of errors beyond its control. Sensaphone also cannot guarantee that changes in equipment made by other manufacturers, and referred to in this manual, will not affect the applicability of the information in this manual.

Copyright © 2007 by SENSAPHONE®

First Edition, version 1.2, June, 2010

Written and produced by Sensaphone

Please address comments on this publication to:

Sensaphone
901 Tryens Road
Aston, PA 19014

Important Safety Instructions

Your Sensaphone 2800 has been carefully designed to give you years of safe, reliable performance. As with all electrical equipment, however, there are a few basic precautions you should take to avoid hurting yourself or damaging the unit:

- Read the installation and operating instructions in this manual carefully. Be sure to save it for future reference.
- Read and follow all warning and instruction labels on the product itself.
- To protect the Sensaphone 2800 from overheating, make sure all openings on the unit are not blocked. Do not place on or near a heat source, such as a radiator or heat register.
- Do not use your Sensaphone 2800 near water, or spill liquid of any kind into it.
- Be certain that your power source matches the rating listed on the AC power transformer. If you're not sure of the type of power supply to your facility, consult your dealer or local power company.
- Do not allow anything to rest on the power cord. Do not locate this product where the cord will be abused by persons walking on it.
- Do not overload wall outlets and extension cords, as this can result in the risk of fire or electric shock.
- Never push objects of any kind into this product through ventilation holes as they may touch dangerous voltage points or short out parts that could result in a risk of fire or electric shock.
- To reduce the risk of electric shock, do not disassemble this product, but return it to Sensaphone Customer Service or another approved repair facility when any service or repair work is required. Opening or removing covers may expose you to dangerous voltages or other risks. Incorrect reassembly can cause electric shock when the unit is subsequently used.
- If anything happens that indicates that your Sensaphone 2800 is not working properly or has been damaged, unplug it immediately and follow the procedures in the manual for having it serviced. Return the unit for servicing under the following conditions:
 1. The power cord or plug is frayed or damaged.
 2. Liquid has been spilled into the product or it has been exposed to water.
 3. The unit has been dropped, or the enclosure is damaged.
 4. The unit doesn't function normally when you're following the operating instructions.
- Avoid using a telephone (other than a cordless type) during an electrical storm. There may be a remote risk of electric shock from lightning.

- Do not use the telephone to report a gas leak in the vicinity of the leak.

CAUTION: To reduce the risk of fire or injury to persons, read and follow these instructions:

1. Replace the battery only with the same or equivalent type recommended by the manufacturer.
2. Do not dispose of the battery in a fire. The cell may explode. Check with local codes for possible special disposal instructions.
3. Do not open or mutilate the battery. Released electrolyte is corrosive and may cause damage to the eyes or skin. It may be toxic if swallowed.
4. Exercise care in handling battery in order not to short the battery with conducting materials such as rings, bracelets, and keys. The battery or conductor may overheat and cause burns.

FCC Requirements

Part 68: The Sensaphone 2800 complies with 47 CFR, Part 68 of the rules. On the side of the unit there is a label that contains, among other information, the Certification Number and the Ringer Equivalence Number (REN) for this equipment. You must, upon request, provide this information to your local telephone company.

The REN is useful to determine the quantity of devices that you may connect to your telephone line and still have all of those devices ring when your telephone number is called. In most, but not all areas, the sum of the REN's of all devices connected to one line should not exceed five (5.0). To be certain of the number of devices that you may connect to your line, you may want to contact your local telephone company to determine the maximum REN for your calling area.

The applicable certification jack USOC for this equipment is: RJ11C. The facility interface code (FIC) for this equipment is: 02LS2.

A compliant telephone cord and modular plug are provided with equipment. This equipment is designated to be connected to the telephone network or premises wiring using a compatible modular jack which is Part 68 compliant. See Installation Instructions for details.

This equipment may not be used on coin service units provided by the telephone company. Connection to party lines is subject to state tariffs. Contact the state public utility commission, public service commission or corporation commission for information.

Should the 2800 cause harm to the telephone network, the telephone company may discontinue your service temporarily. If possible, they will notify you in advance. But if advance notice isn't practical, the telephone company may temporarily discontinue service without notice and you will be notified as soon as possible. You will be informed of your right to file a complaint with the FCC. The telephone company may make changes in its facilities, equipment, operations, or procedures where such action is reasonably required in the operation of its business and is not inconsistent with the rules and regulations of the FCC that could affect the proper functioning of your equipment. If they do, you will be notified in advance to give you an opportunity to maintain uninterrupted telephone service.

If you experience trouble with the 2800, or you need information on obtaining service or repairs, please contact:

Sensaphone
901 Tryens Road
Aston, PA 19014
Toll-Free: 1-877-373-2700
FAX: 610-558-0222

If the equipment is causing harm to the telephone network, the telephone company may ask that you disconnect this equipment from the network until the problem has been corrected or until you are sure that the equipment is not malfunctioning.

Part 15: This equipment has been tested and found to comply with the limits for a Class A digital device, pursuant to Part 15 of the FCC Rules. These limits are designed to provide reasonable protection against harmful interference when the equipment is operated in a commercial environment. This equipment generates, uses and can radiate radio frequency energy and, if not installed and used in accordance with the instructions, may cause harmful interference to radio communications. Operation of this equipment in a residential area is likely to cause harmful interference in which case the user will be required to correct the interference at his own expense.

RF Exposure

WARNING: To satisfy FCC RF exposure requirements for mobile transmitting devices, a separation distance of 20 cm or more should be maintained between the antenna of this device and persons during device operation. To ensure compliance, operations at closer than this distance is not recommended. The antenna used for this transmitter must now be co-located in conjunction with any other antenna or transmitter.

General Requirements for all Automatic Dialers

When programming emergency numbers and (or) making test calls to emergency numbers:

1. Remain on the line and briefly explain to the dispatcher the reason for the call.
2. Perform such activities in the off-peak hours, such as early morning or late evenings.

Canadian Department of Communications Statement

Notice: The Canadian Department of Communications label identifies certified equipment. This certification means that the equipment meets certain telecommunications network protective operational and safety requirements. The Department does not guarantee the equipment will operate to the user's satisfaction.

Before installing this equipment, users should ensure that it is permissible to be connected to the facilities of the local telecommunications company. The equipment must also be installed using an acceptable method of connection. In some cases, the company's inside wiring associated with a single line individual service may be extended by means of a certified connector assembly (telephone extension cord). The customer should be aware that compliance with the above conditions may not prevent degradation of service in some situations.

Repairs to certified equipment should be made by an authorized Canadian maintenance facility designated by the supplier. Any repairs or alterations made by the user to this equipment, or equipment malfunctions, may give the telecommunications company cause to request the user to disconnect the equipment.

Users should ensure for their own protection that the electrical ground connections of the power utility, telephone lines and internal metallic water pipe system, if present, are connected together. This precaution may be particularly important in rural areas.

CAUTION: Users should not attempt to make such connections themselves, but should contact the appropriate electric inspection authority, or electrician, as appropriate.

The Ringer Equivalence Number (REN) assigned to each terminal device denotes the percentage of the total load to be connected to a telephone loop which is used by the device to prevent overloading. The termination on a loop may consist of any combination of devices subject only to the requirement that the total of the Ringer Equivalent Numbers of all the devices does not exceed 5.0. For Sensaphone 2800, the AC Ringer Equivalent Number is 0.6B.

3 YEAR LIMITED WARRANTY

PLEASE READ THIS WARRANTY CAREFULLY BEFORE USING THE PRODUCT.

THIS LIMITED WARRANTY CONTAINS SENSAPHONE'S STANDARD TERMS AND CONDITIONS. WHERE PERMITTED BY THE APPLICABLE LAW, BY KEEPING YOUR SENSAPHONE PRODUCT BEYOND THIRTY (30) DAYS AFTER THE DATE OF DELIVERY, YOU FULLY ACCEPT THE TERMS AND CONDITIONS SET FORTH IN THIS LIMITED WARRANTY.

IN ADDITION, WHERE PERMITTED BY THE APPLICABLE LAW, YOUR INSTALLATION AND/OR USE OF THE PRODUCT CONSTITUTES FULL ACCEPTANCE OF THE TERMS AND CONDITIONS OF THIS LIMITED WARRANTY (HEREINAFTER REFERRED TO AS "LIMITED WARRANTY OR WARRANTY"). IF YOU DO NOT AGREE TO THE TERMS AND CONDITIONS OF THIS WARRANTY, INCLUDING ANY LIMITATIONS OF WARRANTY, INDEMNIFICATION TERMS OR LIMITATION OF LIABILITY, THEN YOU SHOULD NOT USE THE PRODUCT AND SHOULD RETURN IT TO THE SELLER FOR A REFUND OF THE PURCHASE PRICE. THE LAW MAY VARY BY JURISDICTION AS TO THE APPLICABILITY OF YOUR INSTALLATION OR USE ACTUALLY CONSTITUTING ACCEPTANCE OF THE TERMS AND CONDITIONS HEREIN AND AS TO THE APPLICABILITY OF ANY LIMITATION OF WARRANTY, INDEMNIFICATION TERMS OR LIMITATIONS OF LIABILITY.

1. **WARRANTOR:** In this Warranty, Warrantor shall mean "Dealer, Distributor, and/or Manufacturer."
2. **ELEMENTS OF WARRANTY:** This Product is warranted to be free from defects in materials and craftsmanship with only the limitations and exclusions set out below.
3. **WARRANTY AND REMEDY:** Three-Year Warranty — In the event that the Product does not conform to this warranty at any time during the time of three years from original purchase, warrantor will repair the defect and return it to you at no charge.

This warranty shall terminate and be of no further effect at the time the product is: (1) damaged by extraneous cause such as fire, water, lightning, etc. or not maintained as reasonable and necessary; or (2) modified; or (3) improperly installed; or (4) misused; or (5) repaired or serviced by someone other than Warrantors' authorized personnel or someone expressly authorized by Warrantor's to make such service or repairs; (6) used in a manner or purpose for which the product was not intended; or (7) sold by original purchaser.

LIMITED WARRANTY, LIMITATION OF DAMAGES AND DISCLAIMER OF LIABILITY FOR DAMAGES: THE WARRANTOR'S OBLIGATION

UNDER THIS WARRANTY IS LIMITED TO REPAIR OR REPLACEMENT OF THE PRODUCT, AT THE WARRANTOR'S OPTION AS TO REPAIR OR REPLACEMENT. IN NO EVENT SHALL WARRANTORS BE LIABLE OR RESPONSIBLE FOR PAYMENT OF ANY INCIDENTAL, CONSEQUENTIAL, SPECIAL AND/OR PUNITIVE DAMAGES OF ANY KIND, INCLUDING BUT NOT LIMITED TO ANY LABOR COSTS, PRODUCT COSTS, LOST REVENUE, BUSINESS INTERRUPTION LOSSES, LOST PROFITS, LOSS OF BUSINESS, LOSS OF DATA OR INFORMATION, OR FINANCIAL LOSS, FOR CLAIMS OF ANY NATURE, INCLUDING BUT NOT LIMITED TO CLAIMS IN CONTRACT, BREACH OF WARRANTY OR TORT, AND WHETHER OR NOT CAUSED BY WARRANTORS' NEGLIGENCE. IN THE EVENT THAT IT IS DETERMINED IN ANY ADJUDICATION THAT THE LIMITED WARRANTIES OF REPAIR OR REPLACEMENT ARE INAPPLICABLE, THEN THE PURCHASER'S SOLE REMEDY SHALL BE PAYMENT TO THE PURCHASER OF THE ORIGINAL COST OF THE PRODUCT, AND IN NO EVENT SHALL WARRANTORS BE LIABLE OR RESPONSIBLE FOR PAYMENT OF ANY INCIDENTAL, CONSEQUENTIAL, SPECIAL AND/OR PUNITIVE DAMAGES OF ANY KIND, INCLUDING BUT NOT LIMITED TO ANY LOST REVENUE, BUSINESS INTERRUPTION LOSSES, LOST PROFITS, LOSS OF BUSINESS, LOSS OF DATA OR INFORMATION, OR FINANCIAL LOSS, FOR CLAIMS OF ANY NATURE, INCLUDING BUT NOT LIMITED TO CLAIMS IN CONTRACT, BREACH OF WARRANTY OR TORT, AND WHETHER OR NOT CAUSED BY WARRANTORS' NEGLIGENCE.

WITHOUT WAIVING ANY PROVISION IN THIS LIMITED WARRANTY, IF A CIRCUMSTANCE ARISES WHERE WARRANTORS ARE FOUND TO BE LIABLE FOR ANY LOSS OR DAMAGE ARISING OUT OF MISTAKES, NEGLIGENCE, OMISSIONS, INTERRUPTIONS, DELAYS, ERRORS OR DEFECTS IN WARRANTORS' PRODUCTS OR SERVICES, SUCH LIABILITY SHALL NOT EXCEED THE TOTAL AMOUNT PAID BY THE CUSTOMER FOR WARRANTORS' PRODUCT AND SERVICES OR \$250.00, WHICHEVER IS GREATER. YOU HEREBY RELEASE WARRANTORS FROM ANY AND ALL OBLIGATIONS, LIABILITIES AND CLAIMS IN EXCESS OF THIS LIMITATION.

INDEMNIFICATION AND COVENANT NOT TO SUE: YOU WILL INDEMNIFY, DEFEND AND HOLD HARMLESS WARRANTORS, THEIR OWNERS, DIRECTORS, OFFICERS, EMPLOYEES, AGENTS, SUPPLIERS OR AFFILIATED COMPANIES, AGAINST ANY AND ALL CLAIMS, DEMANDS OR ACTIONS BASED UPON ANY LOSSES, LIABILITIES, DAMAGES OR COSTS, INCLUDING BUT NOT LIMITED TO DAMAGES THAT ARE DIRECT OR INDIRECT, INCIDENTAL, SPECIAL OR CONSEQUENTIAL, AND INCLUDING ATTORNEYS FEES AND LEGAL COSTS, THAT MAY RESULT FROM THE INSTALLATION, OPERATION, USE OF, OR INABILITY TO USE WARRANTORS' PRODUCTS AND SERVICES, OR FROM THE FAILURE OF THE WARRANTORS' SYSTEM TO REPORT A GIVEN EVENT OR CONDITION, WHETHER OR NOT CAUSED

BY WARRANTORS' NEGLIGENCE.

YOU AGREE TO RELEASE, WAIVE, DISCHARGE AND COVENANT NOT TO SUE WARRANTORS, THEIR OWNERS, DIRECTORS, OFFICERS, EMPLOYEES, AGENTS, SUPPLIERS OR AFFILIATED COMPANIES, FOR ANY AND ALL LIABILITIES POTENTIALLY ARISING FROM ANY CLAIM, DEMAND OR ACTION BASED UPON ANY LOSSES, LIABILITIES, DAMAGES OR COSTS, INCLUDING BUT NOT LIMITED TO DAMAGES THAT ARE DIRECT OR INDIRECT, INCIDENTAL, SPECIAL OR CONSEQUENTIAL, AND INCLUDING ATTORNEYS FEES AND LEGAL COSTS, THAT MAY RESULT FROM THE INSTALLATION, OPERATION, USE OF, OR INABILITY TO USE WARRANTORS' PRODUCTS AND SERVICES, OR FROM THE FAILURE OF THE WARRANTORS' SYSTEM TO REPORT A GIVEN EVENT OR CONDITION, WHETHER OR NOT CAUSED BY WARRANTORS' NEGLIGENCE, EXCEPT AS NECESSARY TO ENFORCE THE EXPRESS TERMS OF THIS LIMITED WARRANTY.

EXCLUSIVE WARRANTY: THE LIMITED WARRANTY OR WARRANTIES DESCRIBED HEREIN CONSTITUTE THE SOLE WARRANTY OR WARRANTIES TO THE PURCHASER. ALL IMPLIED WARRANTIES ARE EXPRESSLY DISCLAIMED, INCLUDING: THE WARRANTY OF MERCHANTABILITY AND THE WARRANTY OF FITNESS FOR A PARTICULAR USE AND THE WARRANTY OF FITNESS FOR A PARTICULAR PURPOSE AND THE WARRANTY OF NON-INFRINGEMENT AND/OR ANY WARRANTY ARISING FROM A COURSE OF DEALING, USAGE, OR TRADE PRACTICE.

It must be clear that the Warrantors are not insuring your premises or business or guaranteeing that there will not be damage to your person or property or business if you use this Product. You should maintain insurance coverage sufficient to provide compensation for any loss, damage, or expense that may arise in connection with the use of products or services, even if caused by Warrantors' negligence. The warrantors assume no liability for installation of the Product and/or interruptions of the service due to strikes, riots, floods, fire, and/or any cause beyond Seller's control, further subject to the limitations expressed in any License Agreement or other Agreement provided by Warrantors to purchaser.

The agreement between the Warrantors and the Purchaser, including but not limited to the terms and conditions herein shall not be governed by the Convention for the International Sale of Goods. Where applicable, the Uniform Commercial Code as adopted by the State of Delaware shall apply.

4. PROCEDURE FOR OBTAINING PERFORMANCE OF WARRANTY: In the event that the Product does not conform to this warranty, the Product should be shipped or delivered freight prepaid to a Warrantor with evidence of original purchase.

5. LEGAL REMEDIES AND DISCLAIMER: Some jurisdictions may not allow, or may place limits upon, the exclusion and/or limitation of implied warranties, incidental damages and/or consequential damages for some types of goods or products sold to consumers and/or the use of indemnification terms. Thus, the exclusions, indemnification terms and limitations set out above may not apply, or may be limited in their application, to you. If the implied warranties can not be excluded, and the applicable law permits limiting the duration of implied warranties, then the implied warranties herein are to be limited to the same duration as the applicable written warranty or warranties herein. The warranty or warranties herein may give you specific legal rights that will depend upon the applicable law. You may also have other legal rights depending upon the law in your jurisdiction.

6. CHOICE OF FORUM AND CHOICE OF LAW: In the event that a dispute arises out of or in connection with this Limited Warranty, then any claims or suits of any kind concerning such disputes shall only and exclusively be brought in either the Court of Common Pleas of Delaware County, Pennsylvania or the United States District Court for the Eastern District of Pennsylvania.

Regardless of the place of contracting or performance, this Limited Warranty and all questions relating to its validity, interpretation, performance and enforcement shall be governed by and construed in accordance with the laws of the State of Delaware, without regard to the principles of conflicts of law.

Effective date 08/01/2007
Sensaphone
901 Tryens Road
Aston, PA 19014
Phone: 610.558.2700 Fax: 610.558.0222
www.sensaphone.com

Table of Contents

Important Safety Instructions	iii
FCC Requirements	v
Canadian Department of Communications Statement	vii
3 YEAR LIMITED WARRANTY	ix
CHAPTER 1: INTRODUCTION	17
FEATURES	18
LAYOUT	19
CHAPTER 2: INSTALLATION	21
OPERATING ENVIRONMENT	21
Mounting the 2800	21
Locking the Enclosure	22
Grounding	22
Wiring Connectors	23
TURNING THE 2800 ON	24
Backup Battery	24
TELEPHONE LINE	25
Line Seizure	25
HARD-WIRING SENSORS AND TRANSDUCERS	26
INSTALLING WIRELESS SENSORS	27
External Microphone	29
Wiring Recommendations	29
RECOMMENDED ANTENNA ORIENTATION	30
LED INDICATORS	30
CHAPTER 3: QUICK START GUIDE	32
HOW THE KEYPAD COMMANDS WORK	32
ABORTING A COMMAND	32
ERROR MESSAGES	32
ACKNOWLEDGING A FALSE ALARM	33
RECOMMENDED PROGRAMMING STEPS	33

CHAPTER 4: ZONE PROGRAMMING 34

- HOW TO CHOOSE THE RIGHT WIRELESS CHANNEL 34**
- SETTING THE WIRELESS COMMUNICATIONS CHANNEL 35**
- MANUAL ZONE CONFIGURATION (Hard-wired zone only) 40**
- ENABLE/DISABLE ZONE ALARMS 41**
- ENABLE/DISABLE SOUND LEVEL ALARM 42**
- ENABLE/DISABLE POWER. 42**
- CONFIGURE TEMPERATURE SCALE 43**
- CONFIGURE TABLE RANGE FOR 4–20mA SENSORS 44**
- ALARM RECOGNITION TIME 46**
- ALARM LIMITS 49**
- ZONE CALIBRATION. 52**
- SOUND LEVEL CALIBRATION. 53**
- DESIGNATING A ZONE AS UNUSED 55**
- EXIT DELAY 56**
- TEMPERATURE-ONLY STATUS REPORT 57**

CHAPTER 5 : COMMUNICATION PROGRAMMING 58

- DATE and TIME. 59**
- VOICE MESSAGES. 60**
- ID NUMBER 63**
- ALARM DIAL-OUT TELEPHONE NUMBERS 65**
 - Voice Dialout 65**
 - Numeric Pager Dialout 67**
- SPECIAL DIALING OPTIONS 71**
 - Change to Touch-Tone Dialing. 72
 - Special Dialing Code Summary. 72
- DIAL-OUT TEST MODE 72**
 - To manually dial a phone number:. 73
- ALARM ACKNOWLEDGMENT CODES. 74**
 - To erase an Acknowledgment Code: 76
- ALARM HISTORY. 76**
 - Deleting the Alarm History: 77
- tone OR PULSE DIALING 78**
- RINGS UNTIL ANSWER 78**
- CALL DELAY TIME 79**
- INTERCALL TIME 81**
- CALL PROGRESS. 83**

VOICE REPETITIONS **83**
MAX CALLS **84**
TELEPHONE ANSWERING DEVICE (TAD) COMPATIBILITY **86**
LISTEN-IN TIME **86**
REMOTE PROGRAMMING SECURITY CODE (LOCK) **88**
SPEAKER MUTE **89**
CALLBACK ACKNOWLEDGMENT **90**

CHAPTER 6: CONTROLLING THE OUTPUT... 92

AUTOMATIC MODES **92**
MANUAL MODE **93**

CHAPTER 7: OPERATION 96

ALARM DIALOUT AND ACKNOWLEDGMENT **96**
 Alarm Recognition 96
 Alarm Notification 96
 Dialout Note: Call Progress 96
 Alarm Dialout—Voice 96
 Alarm Dialout—Pager 97
ALARM ACKNOWLEDGMENT **98**
 Alarm Acknowledgment—Voice Dialout 98
 Alarm Acknowledgment—Numeric Pager Dialout 99
 Alarm Acknowledgment—Automatic (Max Calls) 100
 Wireless Sensor Diagnostic Alarms 100
CALL-IN STATUS **100**
REMOTE COMMANDS VIA TOUCH-TONE PHONE **101**

CHAPTER 8: WIRELESS SENSORS 106

WSR-0100 WIRELESS INDOOR TEMPERATURE SENSOR **106**
WSR-0101 WIRELESS INDOOR DRY CONTACT SENSOR **111**
WSR-0102 WIRELESS POWER FAILURE SENSOR **116**
WSR-0103 WIRELESS INDOOR HUMIDITY SENSOR **121**
WSR-0104 WIRELESS INDOOR 4-20MA SENSOR **126**
WSR-0105 WIRELESS MOTION DETECTOR **131**
WSR-0106 WIRELESS SPOT WATER DETECTION SENSOR **136**
WSR-0107 WIRELESS ZONE WATER DETECTION SENSOR **140**
WSR-0199 WIRELESS REPEATER **144**

APPENDIX A: Checking Your Sensaphone 2800 for Proper Operation	149
APPENDIX B: Replacing the Back-up Battery	151
APPENDIX C: Troubleshooting the 2800	153
COMMUNICATIONS/DIAL-OUT:	154
TEMPERATURE MONITORING:	157
4–20mA MONITORING:	159
SOUND LEVEL MONITORING:	160
OTHER MONITORING:	161
WIRELESS SENSORS:	164
APPENDIX D: 2.8 and 10K Thermistor Tables	165
APPENDIX E: 2800 Technical Specifications . . .	167
APPENDIX F: 2800 Quick Reference Guide . . .	170
APPENDIX G: Accessories	174
APPENDIX H: Returning Your 2800 for Repair	176
Test Log	182

CHAPTER 1: INTRODUCTION

Congratulations on your purchase of the Sensaphone 2800. The 2800 is a powerful monitoring, alarm, and event logging system. It can monitor equipment and environmental conditions using four wired universal Zones and four wireless sensors with scaleable range, built-in power failure detection, sound level monitoring, and one relay output for manual control, or automatic control from alarms. The Sensaphone 2800 also features user-recordable voice for ID and all monitored zones, numeric paging, and built-in line seizure.

The Sensaphone 2800 is a fully programmable environmental monitoring system for unattended or remote applications. The unit will monitor and alarm on four wired zones: these can be N.O./N.C.(Normally Open or Normally Closed) contact, 4–20mA, or 2.8K or 10K thermistor (temperature sensor). In addition the unit will accept signals from up to four wireless sensors. The unit will also monitor AC power, sound level, and battery condition. On the front of the unit are LED indicators to show the operating status. Each zone (including power, sound and battery) has a status LED indicating the alarm status of the Zone. There is also a LED to indicate if the Output is On, a LED for Phone In-Use status and a LED for System-On status.

The unit is programmed using the built-in keypad and voice response menus. All programming is stored in nonvolatile memory so that all programming is retained even without power. The unit is capable of performing alarm event logging of all eight Zones, power, and sound. The event logging (history) is also stored in nonvolatile memory. A battery-backed real-time clock is also included to time-stamp logged events. The alarm event history can be heard through the built-in speaker or remotely over the telephone. A complete status report of all monitored conditions can also be heard simply by calling the 2800.

The unit comes in a plastic NEMA-4 enclosure with tabs for wall or panel mounting. Terminal connections for Zones, outputs and power are easily accessible from the front of the unit. The 2800 is powered

by a plug-in adapter and has a 6V 3.4AH rechargeable backup battery located behind the panel. Circuitry in the unit will maintain precise charging of the battery system. The unit also includes built-in Line Seizure capability to ensure that the telephone line is available when necessary.

FEATURES

The Sensaphone 2800 Includes the following features:

- Four Wired Zones configurable as temperature, 4–20mA, or dry contact
- Four Wireless Zones compatible with Sensaphone 2800 Series Wireless Sensors. (See Chapter 8)
- Scaleable Range for 4–20mA Zones
- Calibration for each Zone
- Each Zone can be individually enabled or disabled
- Power monitor
- Fully automatic input configuration.
- High sound-level monitor (w/optional external mic)
- 1 relay output (manual or automatic control)
- 14 status LEDs
- Dial out to eight telephone numbers
- User-recordable voice messages
- Alarm dialout via voice and numeric pager
- Built-in Line Seizure
- Microphone for on-site listen-in (w/optional external mic)
- Time-stamped Alarm History
- Surge protection on all Zones, telephone line and power supply
- Rechargeable battery backup
- NEMA-4 enclosure

LAYOUT

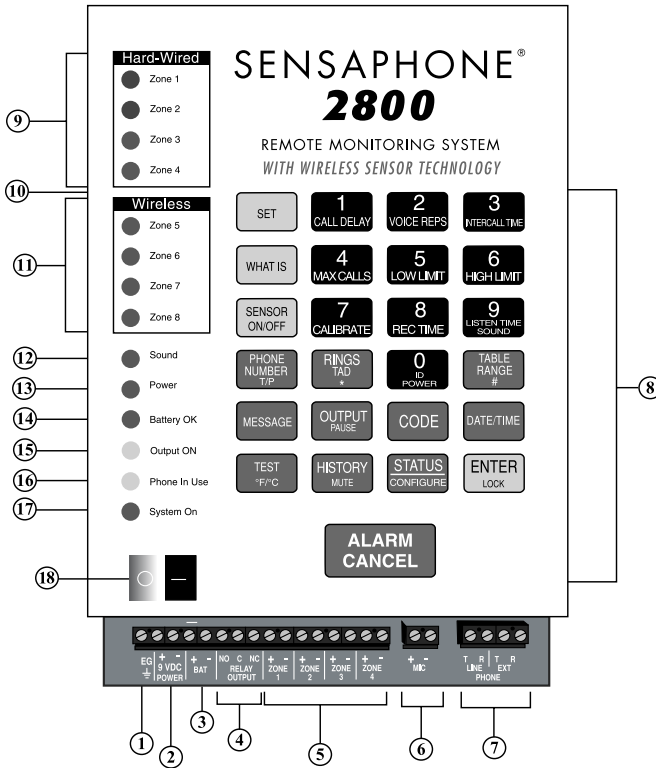

Figure 1: 2800 diagram

- | | |
|--------------------------------------|---------------------------------------|
| 1. Grounding Terminal | 10. Microphone (located behind panel) |
| 2. 9vdc Power Terminals | 11. Wireless Alarm Zone LEDs |
| 3. Battery Terminals | 12. Sound LED |
| 4. Relay Output Terminals | 13. Power LED |
| 5. 4 Zone Terminals | 14. Battery OK LED |
| 6. External Mic Terminals | 15. Output ON LED |
| 7. Phone Network/Extension Terminals | 16. Phone-in-use LED |
| 8. Programming Keypad | 17. System On LED |
| 9. Hard-Wired Alarm Zone LEDs | 18. On/Off Switch |

TECHNICAL SUPPORT

Reading this instruction manual will help you install and program the 2800. Programming and voice recording are performed locally using the built-in keypad. Some programming can also be accessed via touch-tone phone.

If there are any questions or problems that arise upon installation or operation, please contact Technical Support at:

Sensaphone
901 Tryens Road
Aston, PA 19014
Toll-Free Phone: 1-877-373-2700
FAX: 610-558-0222
support@sensaphone.com

CHAPTER 2: INSTALLATION

OPERATING ENVIRONMENT

The Sensaphone 2800 should be mounted and operated in a clean, dry environment. Locate the unit in a central location to insure that all wireless sensors are within range of the 2800. **Do not** install the unit inside of a metal cabinet as this will prevent it from communicating with any wireless sensors. The unit is microprocessor-controlled and as a result it should not be installed near devices that generate strong electromagnetic fields. Such interference is typically generated by power switching equipment such as relays or contactors. A poor operating environment may result in unwanted system resets and/or system lockup. The temperature range the unit can operate in is 32°F to 122°F (0°C to 50°C). If the unit needs to operate below freezing, a heater should be installed nearby.

Mounting the 2800

The NEMA-4 enclosure comes with hardware for wall or panel mounting. The four tabs are attached by screwing the round bubble-end of a tab to each of the four rear corners of the enclosure. Then mount the unit in a position that allows easy access to the Zone terminal block and keypad. Also, there must be a power outlet and telephone jack close to the unit.

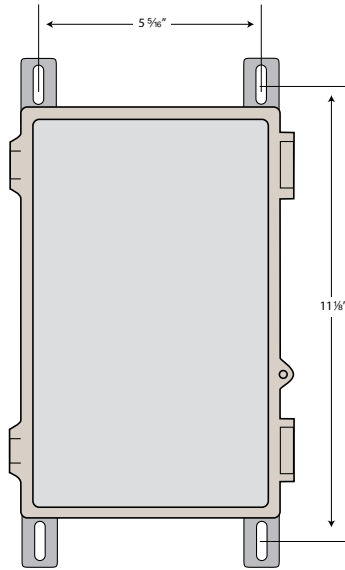

Figure 1: Mounting Dimensions

Locking the Enclosure

The 2800 enclosure can be locked by installing a small luggage-style padlock through the loop on the front door of the enclosure. See Figure below.

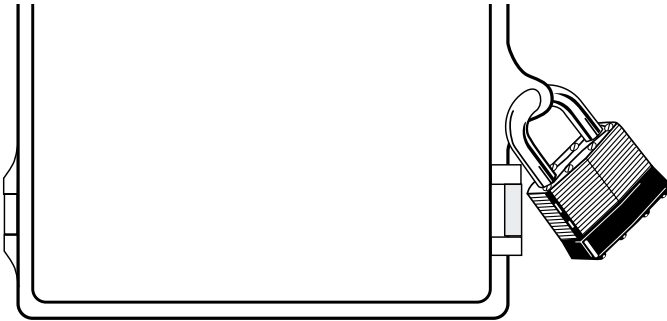

Figure 2: Locking the Enclosure

Grounding

Connect a heavy gauge (#14AWG) copper wire to the earth ground terminal on the left end of the panel and connect the other end to a ground rod or metal cold water pipe (See Figure 3). It is extremely important that the earth ground connection be as short as possible. The ground rod should have sufficient depth to provide a low impedance connection to earth. This connection is required for the surge/lightning protection circuits to function properly.

NOTE: Proper earth grounding of the 2800 is required for warranty coverage.

Ground rods can typically be found at local electrical supply houses and/or hardware stores. Be sure to contact your state “*Call before you dig*” hotline at least **two** days before you install your ground rod, to insure that it is safe to install the ground rod in a chosen area.

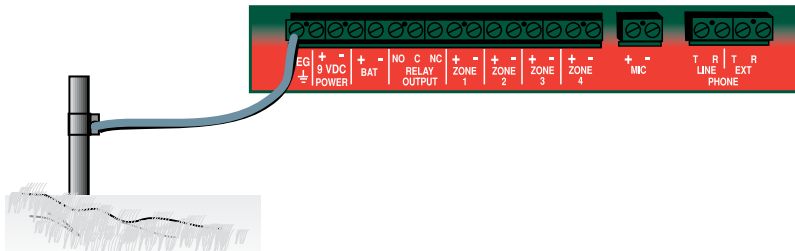

Figure 3: Grounding the 2800

Wiring Connectors

The 2800 includes compression-type liquid-tight connectors for routing wires into the enclosure. To use these connectors, turn them *counter-clockwise to loosen* (or open-up) the compression washer. Insert all cables through the two connectors. When finished turn them *clockwise to secure and seal* the 2800 from the outside environment. If you don't have enough cables to obtain a snug fit you can insert a small piece of soft PVC insulation or rubber tubing to take up the extra space.

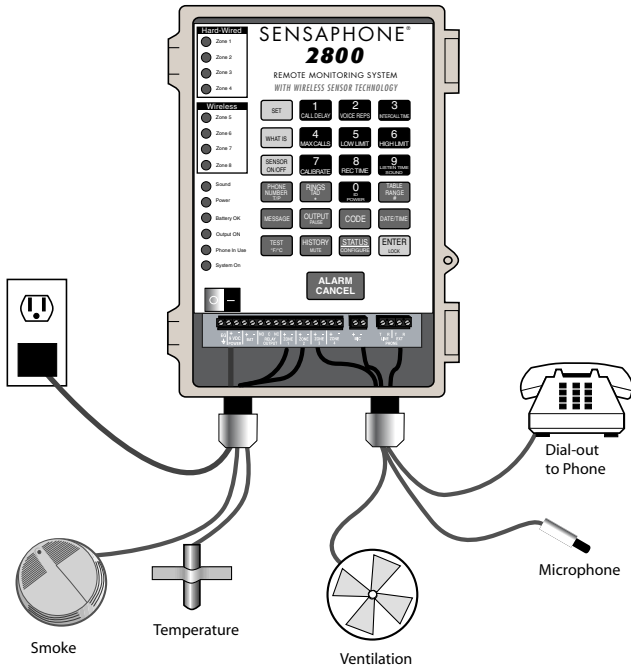

Figure 4: Typical connections from 2800

TURNING THE 2800 ON

Plug the unit's transformer into a 120VAC 60Hz outlet. Toggle the power switch on to start the unit. The System-On LED should glow steadily and the unit will say "Hello." The unit will not turn on if AC power is not present, regardless of the state of the battery.

Note that when the unit is turned off, all programming is retained in non-volatile memory.

Backup Battery

The Sensaphone 2800 includes a 6V 3.4AH sealed lead-acid gel-cell rechargeable battery for system back-up in the event of a power failure. The battery will provide approximately 16 hours of backup time. Actual backup time will depend upon the temperature, battery age, dialing activity, and state of the relay output. The battery is located behind the main panel.

The 2800 will automatically charge the battery whenever the power switch is turned on and the power transformer is plugged in. The battery should provide 3–5 years of service, depending on temperature and charge/discharge cycles, before needing replacement. See Appendix B for battery replacement instructions.

The 2800 also includes a 3V lithium battery to retain the date and time when main power is off. The lithium battery should provide 8-10 years of service life.

NOTE: Have batteries serviced by qualified service personnel only.

TELEPHONE LINE

Connect the 2800's phone jack to a standard 2-wire analog phone line. The unit dials using pulse or tone, with loop start only. The 2800 will recognize ringer frequencies from 16 to 60Hz and will operate with all standard analog telephone systems that accept pulse or tone dialing.

Certain private telephone systems and public switching equipment may not accept the unit's dialing or may generate an unacceptable ring signal. In those cases, a dedicated line may be required for the unit. Consult the supplier of your telephone system if you encounter problems.

CAUTION: Never install telephone wiring during a lightning storm. Never install telephone jacks in wet locations unless the jack is specifically designed for wet locations. Never touch uninsulated telephone wires or terminals unless the telephone line has been disconnected at the network interface. Use caution when installing or modifying telephone lines.

Line Seizure

Line seizure gives the 2800 the ability to “seize” the telephone line when it needs to dial out. For example, if an emergency occurs which puts the 2800 in alarm mode, the unit will be able to dial out even if a telephone has been left off the hook. To the right of the LINE terminals is another set of terminals labeled EXT. These terminals can be used to share the line with other devices (telephone, fax machine, modem) and to give the 2800 priority in the event of an emergency. To make use of this feature you must have all the extension devices originate from the EXT terminals. Whenever the unit must make an alarm phone call, the unit will disconnect any current phone calls and seize the line for its own use. The unit will continue to seize the line until the alarm has been acknowledged. To ease installation, an optional accessory is available (FGD-0060 Line Seizure Kit) which provides an RJ31x modular wall jack, cable, and wiring instructions.

NOTE: The Line Seizure Kit is *not* required for the 2800 seizure capability to function correctly. The Kit allows the disconnection of the 2800 system from the telephone line while ensuring continued telephone operation—useful if the 2800 is, for instance, temporarily removed for service.

HARD-WIRING SENSORS AND TRANSDUCERS

The 2800 hard-wired zones are compatible with NO/NC dry contacts, 2.8K and 10K thermistors, and 4–20mA transducers. To prevent an alarm from occurring while wiring the sensors, it is recommended that the zone alarm be disabled [SENSOR ON/OFF] + [Zone #1–4]. After wiring all of your sensors you will need to configure the zones using the [SET] + [CONFIGURE] command. *See Chapter Four for more information on Disabling Zone alarms and Configuring Zones.*

Recommended sequence for adding a new sensor:

1. Disable the Zone's alarm.
2. Wire up the sensor.
3. Configure the Zone.
4. Enable the Zone.

NOTE: If a false alarm occurs while wiring a sensor, you can quickly acknowledge it by pressing the [ALARM/CANCEL] key. See Chapter Five for more information on User Acknowledgment Codes.

Temperature: The unit will accept 2.8K or 10K thermistors. These should be wired to a Zone terminal and the adjacent ground terminal. For recommended thermistors check the accessory list or thermistor data in the appendices. Thermistor temperature range:

2.8K: -109°F to 115°F (-85°C to 57°C)

10K: -87°F to 168°F (-66°C to 76°C)

Dry Contacts: Only contacts which have no voltage or current applied may be used. Connect the contact to a Zone terminal and an adjacent ground terminal. Do NOT try to monitor a contact that switches 120VAC. This will permanently damage the unit.

4–20mA: A 4–20mA transducer requires you to have an external DC power supply for the transducer. Connect the positive wire of your transducer to the positive terminal of your DC power supply. Connect the negative terminal of the transducer to a Zone terminal on the Sensaphone 2800. Connect the negative terminal from your power supply to the adjacent ground terminal on the 2800.

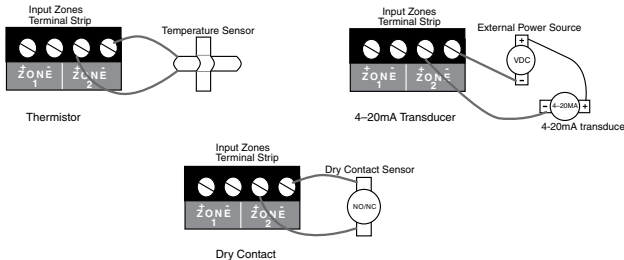
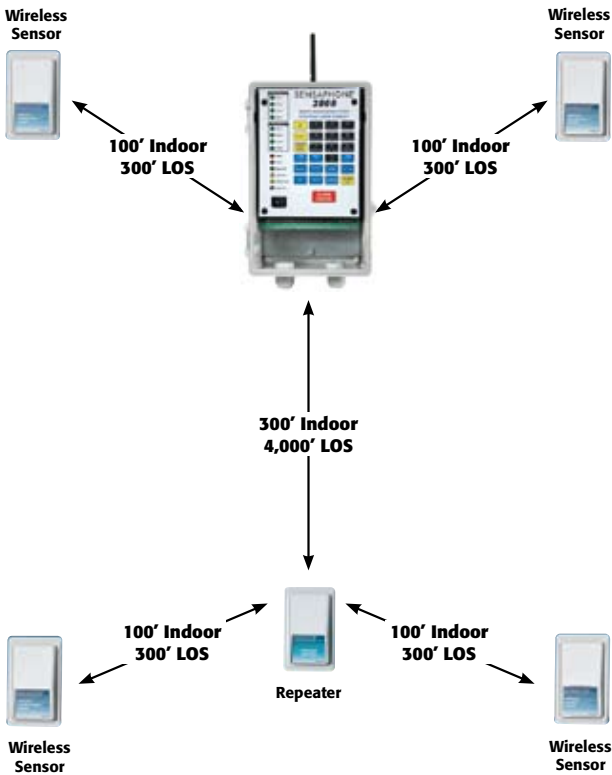

Figure 5: Different Sensor Types connected to the Terminal Block

INSTALLING WIRELESS SENSORS

The 2800 can monitor up to 4 external wireless sensors. Sensors are available to monitor temperature, humidity, power, dry contacts,

4-20mA signals, infrared motion, and water detection. See chapter 8 for specifications on each sensor. The operating distance between the 2800 and each sensor is about 100' indoors or 300' line-of-sight (LOS), depending on the obstructions (walls) and interference sources (other 2.4GHz devices). If the distance from your 2800 to your sensors is too far or there are numerous obstructions, then a wireless repeater must be added between the 2800 and the sensor. The repeater includes a more powerful transceiver and it can be located up to 300' indoors (4,000' line-of-sight) from the 2800. The sensors must still be within 100'/300' of the repeater or the 2800. See diagram below:



NOTE: The “line-of-sight” wireless distance is the maximum distance that the wireless devices can communicate with each other in a best-case scenario. A “line-of-sight” path would be when there are no obstructions at all between the two devices. When the wireless path must go around metal objects or through

walls, the reliable wireless distance will be reduced. When the 2800 is communicating directly with the sensors, the line-of-sight distance is 300 feet, and a typical indoor distance with obstructions is approx. 100 feet. When the 2800 is communicating with a repeater, the line-of-sight distance is 4,000 feet, and the typical indoor distance with obstructions is approx. 300 feet. Experimentation may be required to determine actual wireless range.

External Microphone

An (optional) external microphone may be connected to the MIC terminals to allow remote listen-in capabilities and high sound level detection. (**NOTE:** The built-in microphone is for message recording only.) An external microphone with a 25' cable may be ordered from your Sensaphone supplier: Part number FGD-0057. The microphone connects to the terminals labeled MIC. Be sure to observe proper polarity when connecting the microphone: Red wire to + and Black wire to -. See *Chapter Five for information on programming the Listen-in Time, High Sound Alarm Recognition Time (Chapter 4 – p46), and Sound Level Sensitivity (calibration) (Chapter 4 – p53).*

Wiring Recommendations

The 2800 will work fine in indoor environments using unshielded cable. When wiring will be subject to long lengths (>250') or if run outdoors, it is highly recommended that shielded cable be used and that the shield be connected to an earth ground. Shielded cable should also be used in electrically noisy environments (heavy equipment, pumps, VFDs, etc). Also, be sure to use the appropriate gauge wire based on the distance and sensor type. See chart below:

<u>Wire Gauge</u>	<u>Thermistor</u>	<u>NO/NC Contact & 4–20mA</u>
#24	250'	1000'
#22	500'	2000'
#20	1000'	4000'

When preparing wire for connection to the terminal blocks, strip $\frac{1}{4}$ " of insulation from the conductor (see figure below).



Figure 6: Wire stripped for connection

RECOMMENDED ANTENNA ORIENTATION

For optimal wireless performance it is recommended that the antennas of your sensors and 2800 be oriented as shown below. Note that the transmit power is strongest when the antenna's are parallel to one another as shown by the larger transmit arrows. Orienting the antennas properly will improve signal strength and reduce the number of packet errors that may be caused by antenna cross polarization.

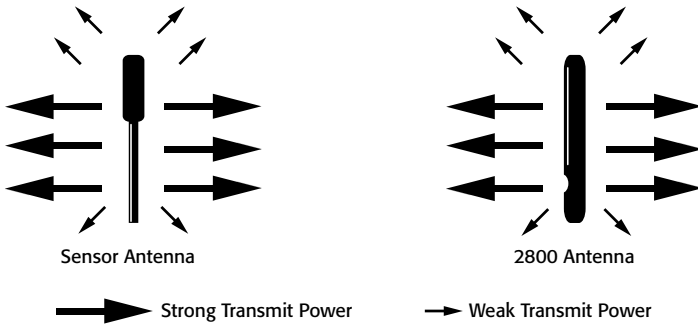

LED INDICATORS

The LEDs provide on-site alarm and status information. Listed below are descriptions of how the LEDs work.

Wired and Wireless Zones:

LED Off: Zone is unused

LED Steady Green: Zone is normal

LED Blinking Green: Alarm condition exists but has not met recognition time

LED Blinking Red: Unacknowledged alarm exists

LED Steady Red: Acknowledged alarm exists

Sound Alarm:

LED Off: Normal

LED Blinking Red: Unacknowledged alarm exists

LED Steady Red: Acknowledged alarm exists

Power Alarm:

LED Off: Normal

LED Blinking Red: Unacknowledged alarm exists

LED Steady Red: Acknowledged alarm exists

Battery Alarm:

LED Steady Green: Battery condition ok

LED Blinking Green: Battery condition low

LED off: No battery/critically low battery condition

Output On:

LED On: Output relay on

LED Off : Output relay off

Phone-In-Use:

LED On: Unit is communicating on the phone line

LED Off: Unit is not using the phone line

System-On:

LED On: System power on

LED Off: System power off

CHAPTER 3: QUICK START GUIDE

This section presents a brief guide and some helpful hints for first-time users of the 2800. Follow the instructions for installation before attempting to program the unit.

HOW THE KEYPAD COMMANDS WORK

The 2800 uses simple keypad commands to program and check all pertinent parameters. All of the keypad commands begin with either the SET, WHAT IS, or SENSOR ON/OFF keys. The SET key is used to program parameters. When performing a programming sequence, the command will typically require the SET key followed by the parameter to be programmed, followed by a value, and then the ENTER key at the end. For example, to program the Call Delay you would press [SET] + [CALL DELAY] + [value] + [ENTER]. To check your programming, you would press the WHAT IS key followed by the parameter (in this case, [WHAT IS] + [CALL DELAY]).

The SENSOR ON/OFF key is generally used to enable and disable functions or to toggle a function on and off. For example, to disable a Zone you would press [SENSOR ON/OFF] + [Zone #] or to turn the speaker Mute on you would press [SENSOR ON/OFF] + [HISTORY/MUTE].

ABORTING A COMMAND

If you are in the middle of a command and you make a mistake, you can abort the command by either pressing the [ALARM CANCEL] key or by simply waiting for the command to time out (typically 30 seconds). When you abort a command, the unit will say “Error 1” to indicate that the command has not been executed successfully.

ERROR MESSAGES

When programming parameters in the 2800 you may get an error message if you inadvertently enter an incorrect value. If the unit says “Error 1,” it means that you entered a value that is out of range or have aborted the command. If Remote Programming Security

Code is enabled (*see Chapter Five*), and you enter the incorrect security code, the unit will answer with “Error 2” and offer you a second chance to enter the correct code.

ACKNOWLEDGING A FALSE ALARM

While programming the unit you may inadvertently set off an alarm. Once an alarm occurs, the unit will start its alarm processing routine, which will prevent you from performing any other keypad function until the alarm is acknowledged. To acknowledge an alarm and stop the unit from making any phone calls, press [ALARM CANCEL]. This will acknowledge the alarm (*assuming that you have not entered any custom acknowledgment codes*). If you have entered one or more custom acknowledgment codes, then enter the code as required.

RECOMMENDED PROGRAMMING STEPS

Listed below are the basic programming steps to get you up and running. The chapters that follow provide detailed programming instructions as well as additional options to customize the operation of your 2800.

Parameter	Chapter #
1. Set the Date & Time	5
2. Configure Zones	4
3. Set Alarm Limits	4
4. Record Zone voice messages	5
5. Record ID voice message	5
6. Set ID number	5
7. Set dialout telephone numbers	5

CHAPTER 4: ZONE PROGRAMMING

This chapter explains the keyboard commands for the monitoring functions of the Sensaphone 2800. This includes:

- Setting the Wireless Communications Channel
- Wireless Zone/Sensor Configuration
- Hard-wired Zone Configuration
- Manual Zone Configuration
- Enable/Disable Zone Alarms
- Enable/Disable Sound Level Alarm
- Enable/Disable Power
- Configure Temperature Scale
- Configure Table Range for 4-20mA Sensors
- Alarm Recognition Time
- Alarm Limits
- Zone Calibration
- Sound Level Calibration
- Designating a Zone as Unused
- Exit Delay
- Temperature-Only Status Report

HOW TO CHOOSE THE RIGHT WIRELESS CHANNEL

Choosing the right wireless channel for your Sensaphone 2800 is important because you may experience interference from other 2.4GHz devices if they are communicating at the same frequency(channel). Some common forms of interference include wireless computer networks, 2.4GHz cordless phones, and microwave ovens. Try to maximize the distance between these devices and your Sensaphone 2800 and sensors. If your Sensaphone 2800 or wireless sensors are in proximity to a wireless network (WiFi) you can reduce the chance of interference by choosing a 2800 wireless channel as far from the WiFi network channel as possible. Use the chart below to select the best wireless channel for your 2800 system.

WiFi Channel	Recommended 2800 Wireless Channel
1	3 or 4
2	3 or 4
3	3 or 4
4	3 or 4
5	1, 3 or 4
6	1 or 4
7	1 or 4
8	1, 2, or 4
9	1 or 2
10	1 or 2
11	1 or 2
12	1, 2, or 3
13	1, 2, or 3
14	1, 2, or 3

SETTING THE WIRELESS COMMUNICATIONS CHANNEL

The Sensaphone 2800 and associated sensors must be set to operate on the same wireless channel. There are four possible channels. If you will be installing more than one 2800 in the same area you must configure each system on its own channel. By default, the 2800 and sensors are set to channel 1. To change the channel on the sensor(s) you must remove the cover and configure the jumpers (see chapter 8). On the 2800 you can set the channel number using the following key sequence.

1. Press SET CONFIGURE keys.



2. Press the # key.



The 2800 will say “Enter channel number”

3. Enter a value between 1-4



4. Press ENTER.



The 2800 will say “ok” after several seconds

WIRELESS ZONE/SENSOR CONFIGURATION

Sensaphone 2800 wireless sensors may be configured individually or all at once. The 2800 can have up to 4 wireless sensors. You can also have 1 repeater to help extend the range of sensors that may be too far from the unit to wirelessly communicate. The 2800 will automatically add sensors in order as Zone 5, 6, 7 & 8. Make sure your sensor(s) have been powered up for at least a minute before starting the configuration procedure. To add one sensor at a time, power up the sensor, wait 1 minute then apply the key sequence below. Repeat this procedure for each additional sensor. To add multiple sensors, power up all of the sensors, wait 1 minute, then enter the key sequence below.

NOTE: This procedure is the same one used to configure your hard-wired sensors. Make sure there are no alarms on zones 1-4 when performing wireless sensor configuration.

To add one or more wireless sensors:

1. Press the SET key.



2. Press the CONFIGURE key.



The 2800 will say “Enter zero for automatic configuration”, “Enter zone number for manual configuration”, “Enter pound (#) for Channel configuration”

3. Press “0”, for automatic sensor configuration.



The 2800 will say the following:

Zone 1 Open/Closed/ Temperature, etc...

Zone 2 Open/Closed/ Temperature, etc...

Zone 3 Open/Closed/ Temperature, etc...

Zone 4 Open/Closed/ Temperature, etc...

Zone 5 Wireless sensor (serial number) humidity, signal strength is 71 percent

Zone 6 Wireless sensor (serial number) temperature, signal strength is 74 percent

Zone 7 Wireless sensor (serial number) power, signal strength is 68 percent

Zone 8 Wireless sensor (serial number) water, signal strength is 79 percent

Make sure each of your sensors has been recognized and assigned to a zone number. The led next to the wireless sensor zone number should be steady green.

NOTE: This procedure will not affect wireless sensors that have already been configured.

Deleting Wireless Sensors

The Sensaphone 2800 monitors each wireless sensor to make sure its is functioning properly. If a sensor is turned off, the 2800 will notify you of a communication error for that particular channel. If you need to permanently delete a sensor from the system, follow the key sequence below:

1. Press the SENSOR ON/OFF key.



2. Press the SET key.



The 2800 will respond “enter zone number”.

3. Press the wireless sensor zone number (5-8).



The 2800 will respond “Wireless sensor x erased”. The led for the selected wireless sensor should turn off.

Wireless Sensor Diagnostics

You can get detailed diagnostic information for each wireless sensor to assist in determining if your wireless sensors are operating properly. The information available includes: battery condition, DC power status, signal strength, and wireless data error rate.

To get Sensor Diagnostics:

- 1) Press WHAT IS.



- 2) Press SENSOR ON/OFF.



The 2800 will say “Enter zone number”

- 3) Press the Wireless Sensor Zone Number (5-8). The 2800 will respond with information for the selected sensor, or press 0 and you will receive diagnostics for all sensors.



A sample report for sensor 5 is described below:

“Wireless sensor 5, temperature”

“The power is off”

“The battery is OK”

“Signal strength is 35 percent”

“Error rate is 0.1 percent”

HARD-WIRED ZONE CONFIGURATION

The 2800 is compatible with normally open, normally closed, 2.8K thermistor (temperature), 10K thermistor (temperature), and 4-20mA type sensors. All of the Zones are configured simultaneously by keying in a simple key sequence after connecting all of your sensors. Make sure all sensors are in their normal state. All 4–20mA transducers should be powered on.

NOTE: New temperature sensors will default configure to 2.8K. If you are connecting any 10K sensors to the 2800, these **must** be configured manually. Any sensor that was previously configured as either 2.8K or 10K will maintain proper thermistor type. (*See the Manual Configuration section*)

To configure the Zone Types:

1. Press the SET key.



2. Press the CONFIGURE key.



The 2800 will prompt, “Enter 0 for automatic configuration, enter zone number for manual configuration.” If you press “0”, the 2800 will scan each Zone input and determine the input type.

The Zones are now considered normal. If a *normally closed* Zone becomes open, an alarm will occur. If a *normally open* Zone becomes closed, an alarm will occur.

MANUAL ZONE CONFIGURATION (Hard-wired zone only)

If you would like to program the Zone type (NO, NC, temperature, 4–20mA) without going through the automatic process that scans all Zones, this command will allow you to configure a single Zone. This command is useful if you have alarms on other channels and cannot use the automatic configuration process, or if you wish to configure the Zone type without actually connecting the sensor.

NOTE: You **MUST** use manual configuration for any zone connecting to a 10K temperature sensor.

To configure the Zone Type:

1. Press the SET key.



2. Press the CONFIGURE key.



The 2800 will prompt, “Enter 0 for automatic configuration, enter zone number for manual configuration.”

3. Press the corresponding Zone key (1–4).



The 2800 will say “Enter Mode.”

4. Press the key which corresponds to the type of Zone according to the table below:

- 1: NO Dry Contact
- 2: NC Dry Contact
- 3: 2.8K Thermistor (temperature sensor)
- 4: 10K Thermistor (temperature sensor)
- 5: 4–20mA

5. Press ENTER.



The 2800 will recite the programmed Zone input configuration.

ENABLE/DISABLE ZONE ALARMS

This function allows you to enable or disable a Zone (1-8) for dialout during an alarm. An enabled Zone will respond to an alarm and allow dialout. A disabled Zone will not initiate a dialout, but it will still be included in the status report, preceded by the word “disabled.” This command is useful while you are wiring your Zones or at any other time you would like the alarms to be ignored. The default setting for all Zones is enabled (*on*).

To enable/disable Zones:

1. Press the SENSOR ON/OFF key.



2. Press the corresponding number key (1–8) of the Zone you want to enable/disable. 2800 will say “Zone (1–8) Alarm On/Off” to indicate enabled or disabled respectively.

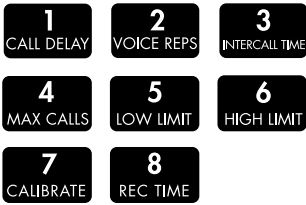

3. Repeat key sequence to change back to previous setting.

ENABLE/DISABLE SOUND LEVEL ALARM

This function allows you to enable or disable the sound alarm for dialout. When enabled, a high sound level at the remote microphone (optional)—*that meets the programmed recognition time and level*—will trip a sound alarm and the unit will dial out. Disabling sound will prevent a sound alarm dialout. The default setting is enabled (*on*).

To enable/disable sound:

1. Press the SENSOR ON/OFF key.



2. Press the Sound Alarm key (9). 2800 will say “Sound Alarm On/Off” to indicate enabled or disabled respectively.



3. Repeat key sequence to change back to previous setting.

ENABLE/DISABLE POWER

This function allows you to enable or disable AC power failure monitoring (0). Enabled AC power monitoring will respond to an alarm and allow dialout. Disabled AC power monitoring will not initiate a dialout alarm. The default setting is enabled (*on*).

To enable/disable power:

1. Press the SENSOR ON/OFF key.

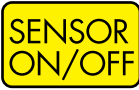

2. Press the power key (0) to enable/disable. 2800 will say “Power Alarm On/Off” to indicate enabled/disabled.



3. Repeat key sequence to change back to previous setting.

CONFIGURE TEMPERATURE SCALE

The 2800 can read temperature in degrees Fahrenheit or Celsius. The default is degrees Fahrenheit.

To change the Temperature Scale:

1. Press the SENSOR ON/OFF key.



2. Press the F/C key.



The 2800 will say “degrees Fahrenheit” or “degrees Celsius” to indicate the current setting. Repeat the key sequence to change back to previous settings.

NOTE: When you change the temperature scale, you must adjust high and low limits accordingly.

CONFIGURE TABLE RANGE FOR 4–20mA SENSORS

The 2800 allows you to create a unique linear table for each 4–20mA sensor. The Table Low (4mA) and Table High (20mA) values are used to define the lower and upper range of your 4–20mA sensor. For example, suppose you are using a 4–20mA transducer to measure the depth of water in a 15 foot well. Simply enter a Table Low value of 0 and a Table High value of 15 and the 2800 will scale the Zone to read between 0 and 15. The low and high table range can be set from -10,000 to +10,000 [Defaults: low=0, high=100]. To make a value negative, precede the value with the [RINGS/TAD/*] key.

To configure the Table Low and High Range:

1. Press the SET key.



2. Press the TABLE RANGE key. 2800 will say “Enter Zone Number.”



3. Press the corresponding Zone number (1–8). 2800 will say “Enter Low Number.”



- Using the number keys, enter the Table Low value, then press ENTER.

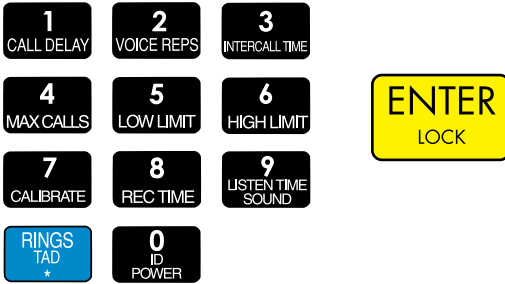

The 2800 will say “Enter High Number.”

- Using the number keys, enter the Table High value and press ENTER.

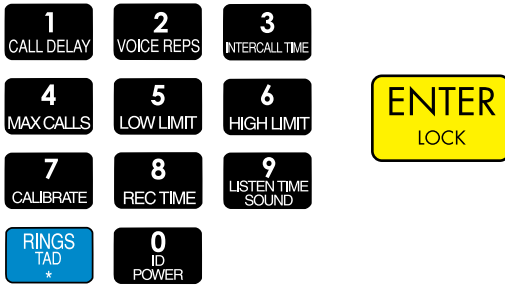

The 2800 will say “OK.”

To play back the Table Low and Table High Range:

- Press the WHAT IS key.



- Press the TABLE RANGE key. 2800 will say “Enter Zone Number.”



3) Press the corresponding Zone number (1–8).

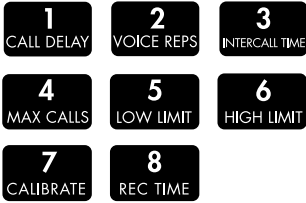

The 2800 will say “Low” and speak the low table value, then it will say “High” and speak the high table value.

ALARM RECOGNITION TIME

The Alarm Recognition Time is the length of time an alert condition must be present before a valid alarm exists and dial-out is activated. If a condition exists and then clears within the recognition time, it is not considered an alarm. This is useful to prevent nuisance dialouts for momentary alarm conditions or on self-correcting equipment. Each Zone can be programmed with a different recognition time, including Power Alarms and Sound Level Alarms. The default recognition time is 3 seconds for all *Zones*, 5 minutes for *Power*, and 8 seconds for *Sound* level. When using the wireless passive infrared sensor the recognition time is fixed at 0 seconds. This is required for proper operation of the sensor. You may program the recognition time for Zone and Power Alarms from 0 seconds up to 540 minutes. Sound Level Alarms may be programmed from 5 to 60 seconds.

NOTE: When the main power fails, the 2800 will announce out loud “Power is OFF” every 15 seconds. It will do this regardless of the programmed recognition time. As a result, when the programmed recognition time is finally met, the unit will dial immediately and not wait the programmed Call Delay time. The Power Alarm is the *only* one treated in this fashion.

To program the Alarm Recognition Time:

1. Press the SET key.



2. Press the REC TIME key. 2800 will say “Enter Zone Number.”



3. Press the corresponding Zone key (1–8), Power(0), or Sound(9).

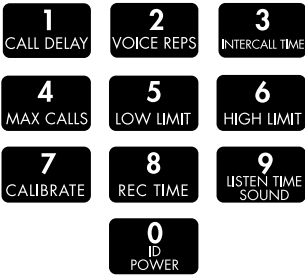

The 2800 will say “Enter minutes.”

4. Using the number keys, enter minutes. Then press ENTER.

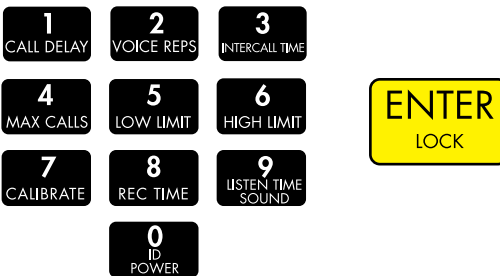

The 2800 will say “OK, enter seconds.”

- Using the number keys, enter seconds. Then press ENTER.

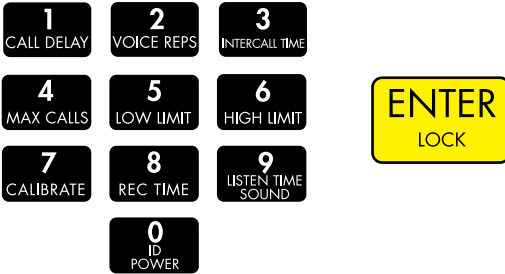

2800 will say “OK.”

To play back the Alarm Recognition Time:

- Press the WHAT IS key.



- Press the REC TIME key.



2800 will say “Enter Zone Number.”

- Press the corresponding Zone key (1–8), Power(0), or Sound (9).

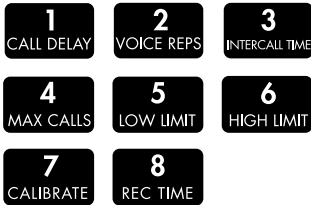

The 2800 will recite the programmed recognition time for that Zone.

ALARM LIMITS

The Alarm Limits determine the level at which a temperature or 4–20mA Zone has reached the alarm threshold. The input value must *exceed* the Alarm Limit to trip an alarm. Each Zone has a programmable Low and High Alarm Limit. The default settings are Low Limit=0 and High Limit=100. The range of programming for 2.8K thermistors is -109° to 115°F (-85° to 57°C). The range of programming for 10K thermistors is -87° to 168°F (-66° to 76°C). For zones configured as 4–20mA, the range of programming is -10,000 to 10,000. To make a value negative, precede the value with the [RINGS/TAD/*] key.

NOTE: Only Zones configured as temperature or 4–20mA can have Alarm Limits programmed.

To program the Low Alarm Limit:

1. Press the SET key.



2. Press the LOW LIMIT key.



The 2800 will say “Enter Zone Number.”

3. Press the corresponding Zone key (1–8).



The 2800 will say “Enter Low Alarm Limit.”

4. Using the number keys, enter a value. Then press ENTER.

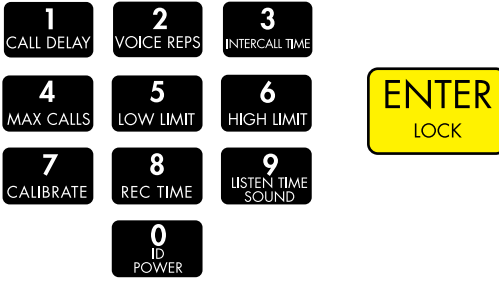

To program the High Alarm

Limit:

1. Press the SET key.



2. Press the HIGH LIMIT key. 2800 will say “Enter Zone Number.”



3. Press the corresponding Zone key (1-8).



The 2800 will say “Enter High Alarm Limit.”

4. Using the number keys, enter a value. Then press ENTER.

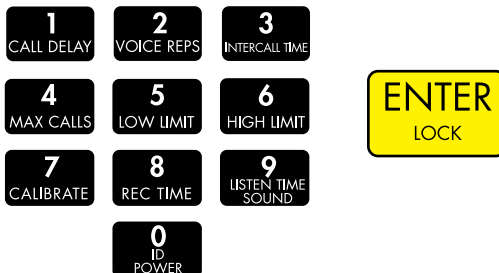

To Play back the Low Alarm Limit:

1. Press the WHAT IS key.



2. Press the LOW LIMIT key. 2800 will say “Enter Zone Number.”



3. Press the corresponding Zone key (1–8). 2800 will say the programmed value.

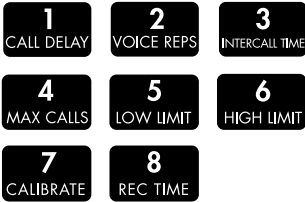

To Play Back the High Alarm Limit:

1. Press the WHAT IS key.



2. Press the HIGH LIMIT key. 2800 will say “Enter Zone Number.”



3. Press the corresponding Zone key (1-8). 2800 will say the programmed value.



ZONE CALIBRATION

Due to tolerance variations or other factors, you may need to program an offset to calibrate the sensor. The offset can range from -15 to +15 for Zones configured as temperature, and -100 to +100 for Zones configured as 4–20mA. Setting a positive number will add that number to the Zone reading. Setting a negative number will subtract the programmed value from the Zone reading. For instance, if a temperature sensor consistently read two degrees high, you could use the calibration feature to adjust that temperature down two degrees. To make a value negative, precede the value with the [RINGS/TAD/*] Key.

To calibrate a Zone:

1. Press the SET key.



2. Press the CALIBRATE key.



The 2800 will say “Enter Zone Number.”

3. Press the corresponding Zone key (1–8).



The 2800 will say “Enter Number.”

4. Enter the number. Then press ENTER.

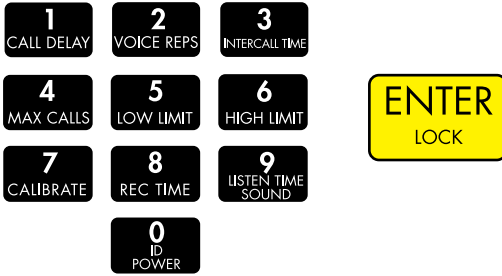

The 2800 will say “OK.”

To play back the present calibration:

1. Press the WHAT IS key.



2. Press the CALIBRATE key. 2800 will say “Enter Zone Number.”



3. Press the corresponding Zone key (1–8).

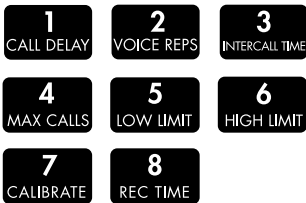

The 2800 will recite the programmed calibration.

SOUND LEVEL CALIBRATION

This feature allows you to program the level of sound that will cause the 2800 to respond to an alarm and dial out.

NOTE: This applies *only* to the (optional) external microphone. It may be useful to desensitize the 2800 to sound if installed in an area with a rela-

tively high noise level, or where a loud noise occurs frequently but is not associated with an alarm. In some applications, it may be desirable to increase sound sensitivity to low sound levels. The sensitivity setting (calibration) for Sound Alarm monitoring ranges from 1 to 160. A value of 1 makes the microphone the MOST sensitive to changes in sound. The value 160 makes the microphone the LEAST sensitive to sound. The default value is 32.

To calibrate the Sound Level:

1. Press the SET key.



2. Press the CALIBRATE key.



The 2800 will say, "Enter Zone Number."

3. Press the SOUND key.



The 2800 responds: "Enter number."

4. Using the number keys, enter a value for sound calibration and press ENTER.



The 2800 will say, "OK."

To play back the Sound Level calibration:

1. Press the WHAT IS key.



2. Press the CALIBRATE key. 2800 will say “Enter Zone Number.”



3. Press the SOUND key.



The 2800 will recite the programmed sound sensitivity level.

DESIGNATING A ZONE AS UNUSED

This feature allows you to mark selected Hard Wired Zones, Power, or Sound as unused, which will prohibit them from going into alarm and will also leave them out of the status report.

NOTE: Programming for the selected Zone will be preserved when the Zone is marked as “unused” and will not be reconfigured if automatic Zone configuration is activated.

To designate a Zone as unused:

1. Press the SENSOR ON/OFF key.



2. Press the SET key.



The 2800 will say “Enter Zone Number.”

3. Press the corresponding number of the Zone you wish to mark as unused.



The 2800 will respond by saying Zone 1–8, Power, or Sound “Off/On.” Repeat the key sequence to place the Zone back in use.

EXIT DELAY

The Exit Delay feature is useful when you are using your 2800 for security monitoring. This feature allows you to exit a building without tripping a security alarm. When tripping an alarm is unavoidable, yet a true alert condition has not actually occurred, the alarm response—including dial-out—can be temporarily suppressed.

The 2800 is able to suppress and then reset its dial-out function automatically through use of the Status Report. This is especially convenient when an alert condition is created upon exiting a monitored door, and there is no way to cancel from the local keypad.

NOTE: The Exit Delay feature applies only to hard-wired Zones configured as NO/NC, wireless NO/NC sensors and wireless passive infrared sensors.

Example: You are planning to exit through a monitored door. Prior to exiting, you initiate a Status Report recitation at the 2800 keypad by pressing [WHAT IS], followed by [STATUS], (key sequence shown below). This allows you the duration of the status report to exit without activating the 2800’s programmed response to an alarm. At the conclusion of the status report, normal alarm response is reactivated.

To use exit delay, initiate the Status Report.

1. Press WHAT IS.



2. Press STATUS.



The 2800 recites the full Status Report; during this time, you are able to exit the monitored area without tripping an alarm.

TEMPERATURE-ONLY STATUS REPORT

You can receive a limited status report that only includes inputs configured as temperature. This can be useful when you don't care to listen to the entire status report.

To initiate a Temperature-only Status Report:

1. Press the WHAT IS key



2. Press the TEST key.



CHAPTER 5 : COMMUNICATION PROGRAMMING

This chapter explains the keyboard commands for programming the communications functions of the 2800. This includes programming, interrogating and/or resetting of:

- Date and Time
- Voice Messages
- ID Number
- Alarm Dial-out Telephone Numbers
- Voice Dialout
- Numeric Pager Dialout
- Special Dialing Options
- Dial-out Test Mode
- Alarm History
- Tone or Pulse Dialing
- Rings Until Answer
- Call Delay Time
- Intercall Time
- Call Progress
- Voice Repetitions
- Maximum Number of Calls
- Telephone Answering Device Compatibility
- Listen-in Time
- Programming Security Code
- Speaker Mute
- Callback Acknowledgment

DATE and TIME

The 2800 has an internal clock/calendar that is used to time-stamp events and maintain alarm history. To program the date and time:

1. Press SET, followed by the DATE/TIME key.



2. The unit will say “Enter the date.” Enter the date in month/day/year (mm/dd/yy) format using two digits for each. For example, if the date was January 7, 2005 you would enter 010705, then press ENTER.



3. Next, the unit will say “OK, enter the time.” Enter the time in 24-hour format (e.g. 3:00PM = 15:00) using hours/minutes (hh/mm) format. For example, if the time was 1:30PM you would enter 1330, then press ENTER.



4. To check the date and time press WHAT IS, followed by DATE/TIME. The unit will announce the date and time.



NOTE: The internal clock is powered by an onboard lithium battery which should provide 8–10 years of service life.

To program only the Date or only the Time, you can simply press the ENTER key when prompted and the unit will keep its current value. For example, to program a new TIME but keep the current DATE, press [ENTER] when prompted for the Date. The unit will keep the current setting and then prompt you to enter the new Time.

VOICE MESSAGES

The 2800's digital speech recording feature allows you to record custom messages for each of the eight Zones and an ID Message. This means that when the 2800 calls you during an alarm, you will hear a personalized Voice Message identifying the unit and telling you exactly what alarm condition exists. You can record a separate message for each of the eight Zones. The message can run a maximum of 4.6 seconds. The ID Message can be a maximum of 5.3 seconds. You can shorten the message length by pressing the ENTER key after reciting the message.

The **ID Message** is used to identify the unit. This could be a particular building name, its location (address or city), or some other identifier.

To program the ID Message:

1. Press the SET key.



2. Press the MESSAGE key. The 2800 will say "Enter Message Number."



3. Press the ID key (number 0 key).



4. When the unit beeps, begin speaking your message into the enclosure near the Zone 4 LED. The unit will say "OK," when the recording time has elapsed; then it will play back your recorded message.

To play back the ID Message:

1. Press the WHAT IS key.



2. Press the MESSAGE key.



3. Press the ID key (number 0 key).



The 2800 will play back your recorded message.

The **Zone Messages** are used to identify the device or condition being monitored such as temperature, humidity, equipment alarms, security alarms, etc.

To program the Voice Message for a Zone:

1. Press the SET key.



2. Press the MESSAGE key. The 2800 will say, “Enter Message Number.”



3. Press the number key for the corresponding Zone.



4. When the unit beeps, begin speaking your message into the enclosure near the Zone 4 LED. The unit will say “OK,” when the recording time has elapsed; then it will play back your recorded message.

To play back the message for a Zone:

1. Press the WHAT IS key.



2. Press the MESSAGE key.



3. Press the corresponding Zone number key.

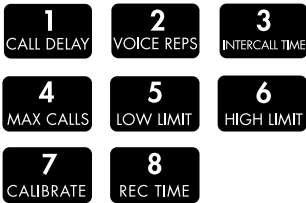

The 2800 will play back your recorded message.

To erase a Zone or ID message:

1. Press the SENSOR ON/OFF key.



2. Press the MESSAGE key.



The 2800 will say “Enter message number.”

3. Press the Zone Number or ID key.



The 2800 will say, “Message erased.”

ID NUMBER

The ID Number is the identification number of the 2800. This number is typically the telephone number where the unit is installed, or it may be designated using any number that best suits your application. The purpose of the ID Number is to immediately provide the source of any alarm, especially when using multiple 2800 units in a complex monitoring system. The ID number is announced during voice alarm messages and displayed on pagers. The ID Number can be up to 16 digits long.

When the 2800 is called from a remote location, it always begins its message with the identification number: “Hello, this is (ID Number).” If no ID Number is programmed, the unit will say, “Hello, this is Sensaphone 2800.”

To program the ID Number:

1. Press the SET key.



2. Press the ID key (number 0 key).



3. The unit will say “Enter ID number.” Using the number keys, enter the unit’s phone number, then press ENTER.

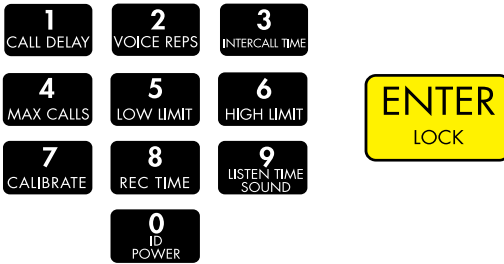

If the number was accepted, the 2800 will say “OK.”

To play back the ID Number:

1. Press the WHAT IS key.



2. Press the ID key (number 0 key).



The 2800 will recite the ID Number.

To erase the ID Number:

1. Press the SET key.



2. Press the ID key (number 0 key).



The 2800 will say “Enter ID Number.”

3. Press the ENTER key.



The 2800 will say “ID Number erased.”

ALARM DIAL-OUT TELEPHONE NUMBERS

The Sensaphone 2800 will dial up to eight 48-digit phone numbers to report alarm conditions. These are the numbers that will be called during an alarm dial-out. The unit can deliver an alarm message via voice telephone call or numeric page. The telephone numbers are dialed sequentially 1 through 8. Therefore, program the first number you want called as Phone #1, the second one as Phone #2, and so on. A pause, pound or asterisk can be added to the phone number to access different phone and beeper systems (see special dialing options). Once the alarm is acknowledged, all dial-out stops.

Voice Dialout

When 2800 calls in Voice mode it will announce the ID Message and the alarm message. Afterward it will ask for the acknowledgement code. If a correct code is entered, the unit will stop dialout. If the wrong code is entered it will hang up and continue dialing the next number.

To program a VOICE dial-out telephone number:

1. Press the SET key.



2. Press the PHONE NUMBER key. The 2800 will say “Enter Number.”



3. Select an assigned phone number (keys 1–8) to represent the new telephone number entry.

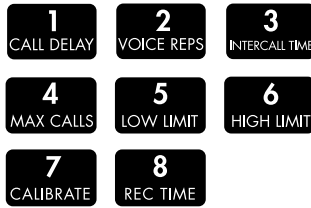

2800 will respond “Enter number.”

4. Enter the phone number using the number keys, and then press ENTER. Be sure to enter “1” + area code if required. If installed on a PBX system, be sure to enter a dialing prefix, such as “9” if required.

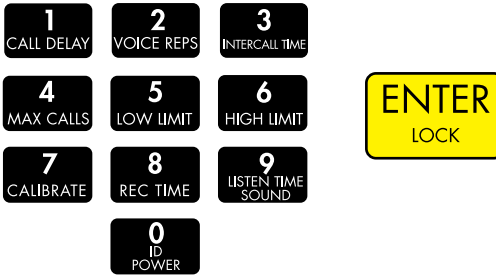

2800 will say “OK.”

To play back a programmed dial-out telephone number:

1. Press the WHAT IS key



2. Press the PHONE NUMBER key. 2800 will say “Enter Number.”



3. Select an assigned Phone number (keys 1–8).

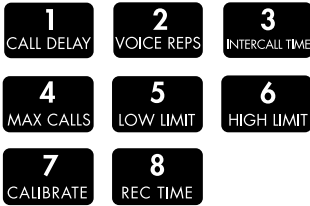

The 2800 will recite the number programmed. If there is no number programmed, 2800 will say “No number.”

To erase a dial-out telephone number:

1. Press the SET key.



2. Press the PHONE NUMBER key. The 2800 will say “Enter Number.”



3. Select an assigned Phone Number (keys 1–8), and press ENTER.

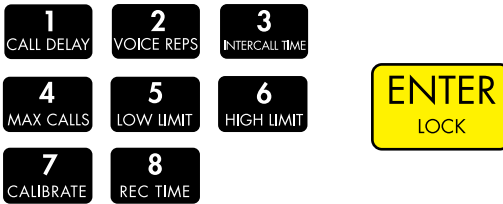

The 2800 will say “Number (1–8) erased.”

Numeric Pager Dialout

When programming the 2800 to dial a Numeric pager there are two methods that can be used: **Automatic** mode and **Manual** mode.

The only difference is that in Automatic mode the 2800 will automatically try to sense when the call has been answered and then send the ID Number and zone numbers. In some instances,

the automatic answer detection and timing from the 2800 is incompatible with the paging service, and the Manual mode must be used.

NOTE: If your phone system requires you to dial a ‘9’ followed by a pause to get an outside line, you *must* use **Manual** mode and insert *pauses* at the end of the number.

When the 2800 calls your Numeric Pager it will leave the programmed ID Number along with the Zone number that is in alarm. If it’s reporting a Power alarm, it will send the ID Number followed by the number “0”; if it’s reporting a Sound alarm, the 2800 will send the ID Number followed by the number “9”. To acknowledge the alarm you will have to call the unit back and enter an acknowledgement code, otherwise the unit will continue dialing the remaining numbers.

To program a NUMERIC PAGER using AUTOMATIC Mode:

1. Press the SET key



2. Press the PHONE NUMBER key. 2800 will say “Enter Number.”



3. Select which Phone number to program. Press any unassigned number key (keys 1–8) to represent the new telephone number entry. 2800 will respond “Enter number.”



4. Press CODE 1 (This tells 2800 this is a Numeric Pager call).



5. Enter the pager number using the number keys. Then press ENTER.

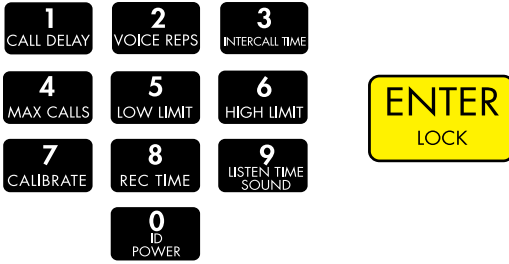

The 2800 will say “OK.”

To program a NUMERIC PAGER using the MANUAL Mode:

1. Press the SET key



2. Press the PHONE NUMBER key. 2800 will say “Enter Number.”



3. Select which Phone number to program. Press any unassigned number key (keys 1–8) to represent the new telephone number entry. 2800 will respond: “Enter number.”



4. Press CODE 1 (This tells 2800 this is a Numeric pager call).



The 2800 will say “Pager.”

5. Enter the pager telephone number using the number keys.



6. Press the PAUSE key twice.



NOTE: Depending on your pager service, you may need to insert a longer or shorter delay (additional/fewer pauses). Two pauses is the recommended starting point. Use the Dial-out Test Mode to help determine the proper number of pauses for your pager service. When it is programmed properly, you will hear the 2800 dial your pager service, then wait (based on the number of pauses) until the call has been answered, and then send another series of Touch-Tones and hang up.

7. Press the ENTER key.



To play back a NUMERIC PAGER number:

1. Press WHAT IS



2. Press the PHONE NUMBER key



3. Select the programmed Phone Number from the number keys (keys 1–8). The 2800 will recite the type of call, “pager,” followed by the pager number assigned to that key.

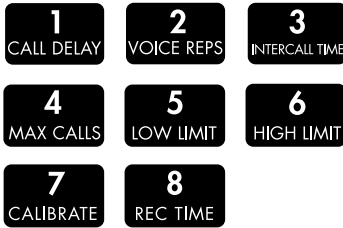

SPECIAL DIALING OPTIONS

The 2800 has provisions for special dialing requirements. These include dialing a * or #, inserting a two-second pause, or forcing the system to wait for the called party to answer. These options are typically used when: (a) the unit is connected to a PBX and must dial a prefix such as ‘9’ or extension to reach an outside line; (b) when dialing a business and stepping through menus to reach a specific extension; or (c) when a pager service is answered by a voice menu. The special dialing commands can be inserted as part of the dialout telephone number. Valid commands are listed below.

- A # tone can be dialed by inserting the TABLE RANGE/# key in the telephone number.



- The * tone can be dialed by inserting the RINGS/TAD/* key in the telephone number.



- A two-second pause can be inserted in the dialout telephone number by pressing the PAUSE key.



- The 2800 can be instructed to wait for the call to be answered before dialing additional digits. This is useful if you need to call a company's main number and then dial additional digits to go to a specific extension (Example: 888-555-1200—wait for answer—227). Note that the unit will automatically wait for answer after dialing the last programmed digit. Press CODE 2 to make the unit wait for an answer, as in the example.



Change to Touch-Tone Dialing

In a situation where you must use pulse dialing, pressing CODE 3 will change all following digits to Touch-Tone.



Special Dialing Code Summary

Special Dialing Codes for the 2800 are:

- Code 1: Numeric pager type
- Code 2: Wait for answer
- Code 3: Change to Touch-Tone

DIAL-OUT TEST MODE

The 2800 allows you to test your telephone programming by simulating an alarm dialout to any programmed telephone number. This can be a valuable tool for insuring that your programming is correct and also for troubleshooting dialing problems. In this mode all signals on the telephone line are audible through the local speaker.

To test a dialout phone number:

1. Press the SET key.



2. Press the TEST key.



The 2800 will say “Enter Number.”

3. Press a number key (1–8) corresponding to the phone number entry you wish to test, and press ENTER.



The 2800 will dial the number and announce the date and time for voice calls, or send its ID number for pager calls.

To manually dial a phone number:

1. Press the SET key.



2. Press the TEST key.



The 2800 will say “Enter number.”

3. Press 0 then enter to enter manual dialing mode. The 2800 will go off-hook and you should hear a dial tone through the speaker. Press any number keys to dial a telephone number.



4. Press ALARM CANCEL to hang up and exit the test.



ALARM ACKNOWLEDGMENT CODES

When the 2800 detects an alarm, it starts dialing each telephone number until it receives acknowledgment or reaches the maximum number of calls. There are two acknowledgment modes: The default, Single-User mode, is for users who are not concerned with knowing who responds to and acknowledges the alarm. In this mode, the default code of “555” is used. In Single-User mode an alarm can be acknowledged by pressing the ALARM CANCEL button on the keypad, or by entering the *Acknowledgment Code* of 555 over the telephone using touch tones.

In Multiple-User mode, up to 8 custom Acknowledgment Codes can be created in order to track who acknowledges alarms. These are 5-digit custom codes, replacing the default “555.” The 5-digit Acknowledgment Code comprises the user’s entry number (1–8) plus a four-digit number. Up to eight different Acknowledgment Codes may be programmed into the unit to identify individual users in the Alarm History Log.

When the unit makes a telephone call in *Voice* mode it will prompt the user to enter an Acknowledgment Code. If this is entered correctly, the 2800 will say “Alarm Acknowledged.” When an alarm message is sent to a *pager*, the person who receives the page will have to call the unit back to acknowledge the alarm. In Single-User mode, the user must enter “555” to acknowledge the alarm. In Multiple-User mode, the user must enter his or her 5-digit Acknowledgment Code.

To Program Multiple-User Acknowledgment Codes:

1. Press SET



2. Press CODE



The 2800 will say “Enter Code Number.”

3. Press a number (1–8) to assign the user.

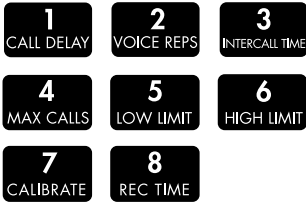

The 2800 will say “Enter code.”

4. Enter the additional four digits of your personal code.

The 2800 will say “OK.”

To play back an Acknowledgment Code:

1. Press WHAT IS



2. Press CODE



3. Press an assigned number entry 1–8.

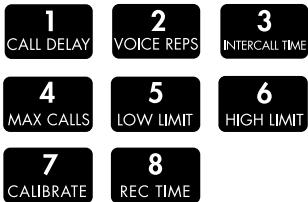

The 2800 will recite the Acknowledgment Code for the selected telephone number entry.

NOTE: In default Single-User mode, the unit will announce “555” immediately after pressing the CODE key.

To erase an Acknowledgment Code:

1. Press the SET key.



2. Press the CODE key.



The 2800 will say “Enter Code Number.”

3. Press an assigned user number, 1–8.



4. Press the ENTER key.



The 2800 will say “Code [number] Erased.”

NOTE: If no User Codes are programmed, the unit automatically defaults to Single-User mode (i.e., the default code of “555”).

ALARM HISTORY

The 2800 will retain historical information on the last 10 alarms. The information retained includes: Zone number, the time/date that the alarm occurred, and the User number that acknowledged the alarm.

To hear the Alarm History:

1. Press the WHAT IS key.



2. Press the HISTORY key.



The unit will recite the history for the last 10 alarms. A sample report is shown below:

“Zone 1 (custom message) alarm high at 3:31PM April 8, 2007
acknowledged by number 4”

“Zone 8 (custom message) alarm low at 2:35AM March 27, 2007
acknowledged by number 1”

In Single-User mode, the report will state “Alarm acknowledged” for alarms acknowledged via telephone. It will state “Manual acknowledgment” for alarms acknowledged at the keypad. In Multiple-User mode, the report will state the user number that acknowledged the alarm. If the maximum number of calls have been made, the report will state “Automatic acknowledgment.”

Deleting the Alarm History:

The Alarm History can be deleted by pressing SET, then HISTORY.



The 2800 will say “Erased.”

TONE OR PULSE DIALING

The 2800 can dial out in pulse or touch-tones. All numbers will be called using the chosen dialing method. The default is TONE.

To program as either Tone or Pulse:

1. Press the SENSOR ON/OFF key.



2. Press the PHONE NUMBER(T/P) key.



The unit will say “Tone” to indicate that Tone dialing is enabled, it will say “Pulse” when pulse dialing is enabled.

RINGS UNTIL ANSWER

The Rings Until Answer is the number of rings that must occur before 2800 answers the phone. This value can be from 1 to 15. The default value is 4.

To program Rings Until Answer:

1. Press the SET key



2. Press the RINGS key.



The 2800 will say “Enter number.”

3. Using the number keys, enter a value and press ENTER.



The 2800 will say “OK.”

To play back the Rings Until Answer:

1. Press the WHAT IS key



2. Press the RINGS key.



The 2800 will recite the programmed value.

CALL DELAY TIME

The call delay time is the length of time the 2800 will announce an alarm before it starts the dial-out sequence. This only applies to the first call. To set delay time *between* calls, see INTERCALL TIME. The default call delay time is 30 seconds. It can be programmed from 0 to 60 minutes. The purpose of Call Delay is to allow time for personnel at the 2800’s installation sight to respond to and cancel an alarm before dial-out begins. During this time, the unit will audibly repeat its “alarm” message and the front panel alarm LED will blink.

To program call delay time:

1. Press the SET key.



2. Press the CALL DELAY key.



The 2800 will say “Enter minutes.”

3. Enter the number of minutes using the number keys. Then press ENTER. To keep the previous setting, just press ENTER.

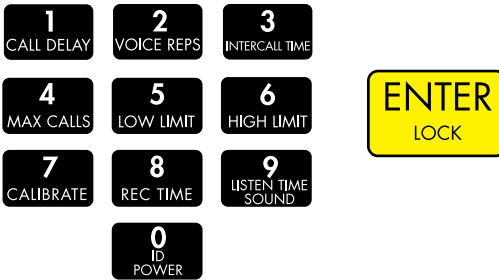

The 2800 will say “Enter Seconds.”

4. Using the number keys, enter the number of seconds, and then press ENTER. To keep the previous setting, just press ENTER.

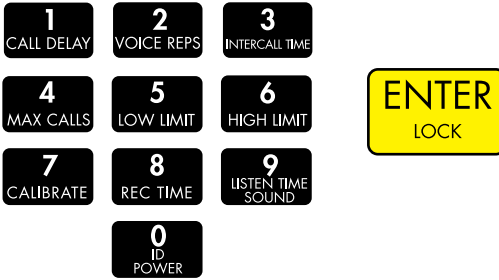

The 2800 will say “OK.”

To play back the call delay time:

1. Press the WHAT IS key



2. Press the CALL DELAY key



The 2800 will recite the programmed time.

INTERCALL TIME

The Intercall Time is the programmable period of time the 2800 waits between making alarm phone calls. Intercall Time is activated ***only after alarm dial-out to the first telephone number fails to be acknowledged.*** This period can be programmed from 10 seconds to 60 minutes. The default Intercall Time is 30 seconds.

TIP: When the 2800 is programmed to make calls to pagers, make sure the intercall delay time is long enough to give the person carrying the pager some time to get to a phone to call the unit back.

If an incoming telephone call is received by the 2800 during the Intercall Time (in between dialing of subsequent telephone numbers to report an alarm), it will answer the incoming call and immediately report any existing alarms. The manner in which the incoming call is answered depends upon whether or not TAD is enabled or disabled (*See Telephone Answering Device (TAD) compatibility*):

If TAD is disabled (default), Rings Until Answer will be the programmed number of rings.

If TAD (Telephone Answering Device) is enabled, Rings Until Answer will be **1**.

To program intercall time:

1. Press the SET key.



2. Press the INTERCALL TIME key.



The 2800 will say “Enter minutes.”

- Using the number keys, enter the number of minutes, and then press ENTER. To keep the previous setting, just press ENTER.

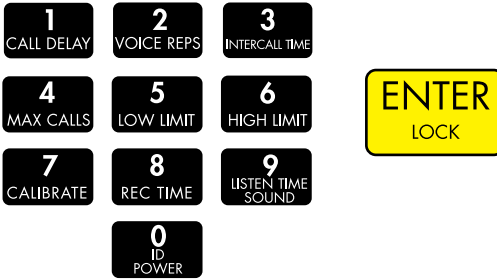

The 2800 will say “Enter seconds.”

- Using the number keys, enter the number of seconds, and press ENTER. To keep the previous setting, just press ENTER.

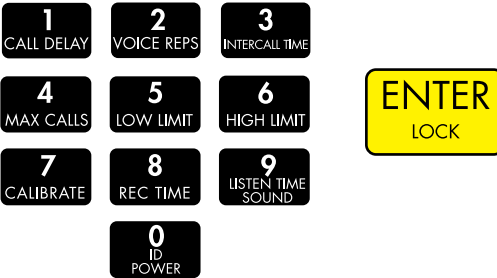

The 2800 will say “OK.”

To play back the Intercall Time:

- Press the WHAT IS key



- Press the INTERCALL TIME key



The 2800 will recite the programmed time.

CALL PROGRESS

The 2800 monitors call progress when it dials out for an alarm. If 2800 encounters a busy signal or receives no answer after ten rings, the unit hangs up, waits the programmed intercall time and then dials the next phone number. When dialing some beeper/pager services, the line may be answered before receiving a ringback. This may interfere with the call progress detection and result in a failed call to certain phone systems or beeper/pager services. If this occurs, disable call progress detection. Default setting is *Enabled*.

To enable/disable call progress detection:

1. Press the SENSOR ON/OFF key.



2. Press the STATUS/CONFIG key.



The 2800 will respond “Call Progress Enabled/Disabled” to indicate that call progress has been turned on or off respectively.

3. Repeat key sequence to change back to previous settings.

VOICE REPETITIONS

The voice repetitions is the number of times the 2800 will recite the alarm message per phone call when it dials out. This can be programmed from 1 to 10 repetitions. The default value is 3 repetitions.

To program the voice repetitions:

1. Press the SET key



2. Press the VOICE REPS key.



The 2800 will say, “Enter number.”

3. Using the number keys, enter a value and then press ENTER.

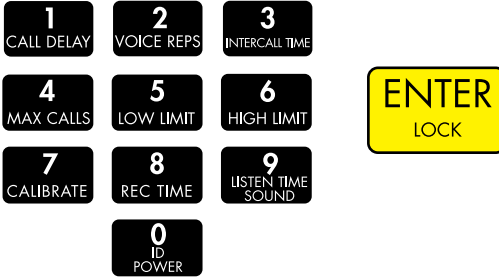

The 2800 will say “OK.”

To play back the number of voice repetitions:

1. Press the WHAT IS key.



2. Press the VOICE REPS key.



The 2800 will recite the number programmed.

MAX CALLS

The 2800 has the ability to acknowledge itself by using the Max Calls function. The unit keeps a count of the number of phone calls it makes for a particular alarm. Once the number of calls made reaches Max Calls, the 2800 will acknowledge the alarm and stop the dialout process. The unit indicates it has reached max calls by saying “alarm acknowledged by (ID Number).” The max calls can be programmed from -1 to 255. The default is 100.

NOTE: If only one Phone Number is programmed, 2800 will dial a maximum of 15 times, regardless of the programmed value of max calls, as required by FCC rules.

To program Max Calls:

1. Press the SET key.



2. Press the MAX CALLS key.



2800 will say “Enter number.”

3. Using the number keys, enter a value, then press ENTER.

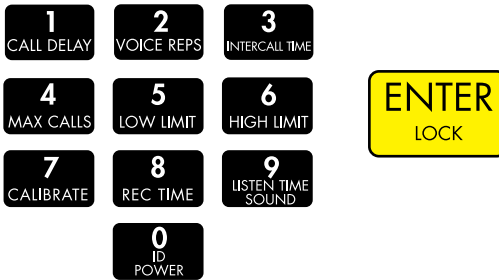

The 2800 will say “OK.”

To play back Max Calls:

1. Press the WHAT IS key.



2. Press the MAX CALLS key.



The 2800 will recite the value of max calls.

TELEPHONE ANSWERING DEVICE (TAD) COMPATIBILITY

The 2800 can be used on the same telephone line as a telephone answering device, such as an answering machine, fax machine, or modem. This feature allows you to call in to the 2800 and bypass the answering device. Default setting is *Off [disabled]*.

To use TAD:

1. Program the 2800's Rings Until Answer to a greater number than the rings until answer for your answering device. For example, 2800 RINGS = 5, device rings = 3.
2. Press the SENSOR ON/OFF key.

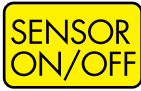

3. Press the TAD key.



The 2800 will say "TAD On." (If the 2800 says "TAD Off" repeat steps 2 and 3.)

4. Once TAD is on, allow the phone to ring once when you call the unit and then hang up. The 2800 recognizes that a call was made and activates a 30 second internal timer. This allows you 30 seconds to call the 2800 back.
5. Wait five seconds then call back within 30 seconds. The 2800 will override the answering device on this incoming call and answer the phone on the first ring. The 2800 resets the TAD timer after one incoming call is received. If you want to call the unit again, you must repeat steps 4 and 5.

LISTEN-IN TIME

The Listen-In Time is the amount of time you can listen to sounds at the unit's location during a status call-in. An external microphone (optional) is required to listen in to on-sight sounds. The programmable range is 0 to 255 seconds. The default setting is 0 seconds (disabled).

To program the Listen-In Time:

1. Press the SET key.



2. Press the LISTEN TIME key.



The 2800 will say “Enter seconds.”

3. Using the number keys, enter the seconds, then press ENTER.

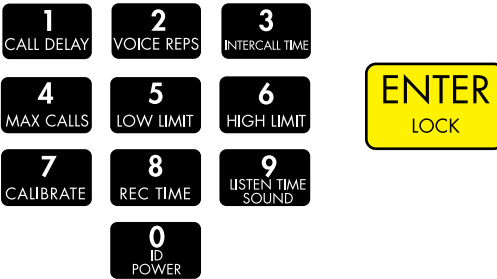

The 2800 will say “OK.”

To play back the Listen-in Time:

1. Press the WHAT IS key.



2. Press the LISTEN TIME key



The 2800 will recite the time programmed.

REMOTE PROGRAMMING SECURITY CODE (LOCK)

The 2800 can be locked to prevent unauthorized call-in access to its programming. You may, however, listen to a status report without unlocking the 2800. To remotely edit programming parameters or

record messages, you must call in and unlock the 2800 by entering the four-digit lock/unlock code.

If you enter the correct code, you will gain access to the 2800 to use the phone commands. If you enter the incorrect code, the 2800 will say “Error 2” and allow you a second chance to enter the correct code. If the second attempt is also wrong, the unit will say “Error 2, good-bye” and disconnect. You cannot program or change the lock code remotely.

For an explanation of how to use remote programming, see Chapter Seven.

To set the security code:

1. Press the SET key.



2. Press the LOCK key.



The 2800 will say “Enter security code.”

3. Using the number keys, enter 4 digits, and press ENTER.

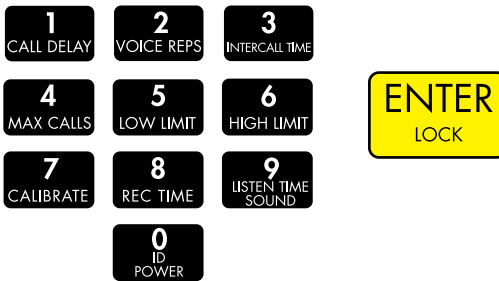

The 2800 will say “OK.”

To play back the security code:

1. Press the WHAT IS key.



2. Press the LOCK key.



The 2800 will recite the security code.

To remove the security code:

1. Press the SET key.



2. Press the LOCK key.



The 2800 will say “Enter security code.”

3. Press ENTER.



The 2800 will say “Security code erased.”

SPEAKER MUTE

When the 2800 dials out with an alarm, it recites the alarm message over the phone and from its internal speaker. The Speaker Mute command allows you to silence the 2800’s internal speaker.

To Mute the speaker:

1. Press the SENSOR ON/OFF key.



2. Press the MUTE key



The 2800 will say “Mute On” to indicate that the speaker mute is on. It will say “Mute Off” to indicate when the speaker mute is off.

3. Repeat key sequence to change back to previous setting.

CALLBACK ACKNOWLEDGMENT

This is an optional feature that can be enabled using the keypad (*default=disabled*). It allows an alarm to be acknowledged simply by calling the unit and letting the line ring 10 times. When this feature is enabled it will temporarily make the Rings Until Answer set to 10 when an unacknowledged alarm exists. If you receive a call via Voice or Pager and are unable to send touch-tones, you can call the unit back, let the line ring 10 times, and the unit will answer and say “...Alarm Acknowledged.”

NOTE: If TAD is also enabled, then you must call the 2800, let it ring once, hang up, and then call the unit back within 30 seconds. The unit will answer on 1 ring and acknowledge the alarm.

To Enable the Callback Acknowledgment Feature:

1. Press SENSOR ON/OFF.



2. Press CODE.



The 2800 will say “Callback Acknowledgment Enabled/Disabled” to indicate that Callback Acknowledgment is enabled. Repeat the key sequence to disable.

CHAPTER 6: CONTROLLING THE OUTPUT

The 2800 includes a relay output that can be used to control a light, siren, or other device. The output is a Form-C Normally Open/ Normally Closed mechanical relay and is rated for up to 120VAC 2A. A sample wiring diagram is shown below:

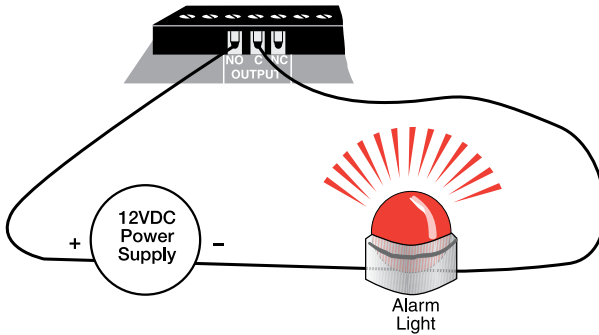

Figure 1: Relay output connected to alarm

The output can be programmed to operate in one of 7 automatic modes or it can operate in manual mode (default). The 7 *automatic* modes allow the output to automatically turn on and off based on individual alarms or any alarm. In *manual* mode the output is controlled via keypad command or remotely via touch-tone phone (See Chapter 7). A description of each mode is shown below:

AUTOMATIC MODES

Mode 1: Output on when zone 1 goes into alarm. Off when alarm is acknowledged.

Mode 2: Output on when zone 2 goes into alarm. Off when alarm is acknowledged.

Mode 3: Output on when zone 3 goes into alarm. Off when alarm is acknowledged.

Mode 4: Output on when zone 4 goes into alarm. Off when alarm is acknowledged.

Mode 5: Output on when zone 5 goes into alarm. Off when alarm is acknowledged.

Mode 6: Output on when zone 6 goes into alarm. Off when alarm is acknowledged.

Mode 7: Output on when zone 7 goes into alarm. Off when alarm is acknowledged.

Mode 8: Output on when zone 8 goes into alarm. Off when alarm is acknowledged.

Mode 9: Output on when a Sound alarm occurs. Off when alarm is acknowledged.

Mode 10: Output on when a Power alarm occurs. Off when alarm is acknowledged.

Mode 11: Output on when any alarm occurs. Off when all alarms are acknowledged.

MANUAL MODE

Mode 0: Output controlled manually via keypad command or touch-tone telephone.

When programmed for Manual mode, the command to switch the output is:

SENSOR ON/OFF + OUTPUT.



The 2800 will respond “ON” or “OFF” to indicate the state of the output.

Note: If the 2800 says “Error,” the output is not programmed for manual mode.

To program the Output Mode:

1. Press the SET key.



2. Press the OUTPUT key.



The 2800 will say “Enter output mode.”

3. Using the number keys, enter a value for the output mode.



4. Press the ENTER key.



The 2800 will say “OK” and recite a description of the mode selected, such as “Automatic on Zone 1” or “Manual.”

NOTE: When *Mode 11* is selected, the 2800 will simply say “Automatic on Alarm,” meaning that the output will automatically turn on when any alarm occurs.

To play back the programmed Output Mode:

1. Press WHAT IS.



2. Press OUTPUT.



The 2800 will recite the programmed output mode.

CHAPTER 7: OPERATION

After installation and programming have been completed, the Sensaphone 2800 is fully operational. This chapter explains how the 2800 operates.

ALARM DIALOUT AND ACKNOWLEDGMENT

There are three stages to a complete alarm event: 1) Alarm Recognition, 2) Alarm Notification, 3) Acknowledgment.

NOTE: Not all alert conditions will go through each stage. For example, some may not meet the recognition time.

Alarm Recognition

1. The 2800 monitors eight zones plus sound level and power failure. When the status of a zone changes or exceeds user-programmed limits, it causes an alert condition.
2. If the alert condition lasts long enough to meet its programmed recognition time, the alert condition becomes an alarm and the 2800 begins the alarm notification sequence.

Alarm Notification

The 2800 can make two types of phone calls: Voice and Numeric Pager.

Dialout Note: Call Progress

The 2800 monitors call progress when dialing out. If the 2800 dials out and encounters a busy signal or no answer after 10 rings, the unit hangs up, waits the programmed intercall delay time, and then dials the next phone number.

NOTE: Dial-tone and call-progress detection may optionally be disabled.

Alarm Dialout—Voice

When dialing out to a destination programmed as “voice,” the 2800 waits for the phone to be answered, then recites its user-recorded identification message, then the message identifying the zone or zones that have gone into alarm.

Below is an example of what the 2800 might say during a typical “voice” dialout:

“Hello, this is 555-2278, ‘Acme Medical Laboratory,’ Zone One, ‘Temperature in Refrigerator One,’ a high temperature alarm exists, it is now 50 degrees Fahrenheit, too high. Listen to sound for ten seconds.”

“Hello, this is 555-2278, ‘Acme Medical Laboratory,’ Zone One, ‘Temperature in Refrigerator One,’ a high temperature alarm exists, it is now 50 degrees Fahrenheit, too high. Listen to sound for ten seconds.”

“Hello, this is 555-2278, ‘Acme Medical Laboratory,’ Zone One, ‘Temperature in Refrigerator One,’ a high temperature alarm exists, it is now 50 degrees Fahrenheit, too high. Listen to sound for ten seconds.”

“Enter acknowledgment code.”

In this example, the number of Voice Message Repetitions was set to three.

NOTE: If the call reaches an answering machine, the message will be recorded, but the 2800 will be talking over your outgoing message, so you will probably lose part of the first alarm message repetition.

Alarm Dialout—Pager

When dialing out to a destination programmed as “Numeric Pager,” the 2800 leaves its programmed ID number on the display of a numeric pager along with the zone number(s) in alarm.

IMPORTANT: When dialing out to a phone number programmed as “Numeric Pager,” **the 2800 DOES NOT** speak a voice message. It calls the pager company or service, enters the number to be displayed on the beeper, then hangs up.

ALARM ACKNOWLEDGMENT

Alarm Acknowledgment—Voice Dialout

Repeated below is the same example of what the 2800 might say during a typical “voice” dialout:

“Hello, this is 555-2278, ‘Acme Medical Laboratory,’ Zone One, ‘Temperature in Refrigerator One,’ a high temperature alarm exists, it is now 50 degrees Fahrenheit, too high. Listen to sound for ten seconds.”

“Hello, this is 555-2278, ‘Acme Medical Laboratory,’ Zone One, ‘Temperature in Refrigerator One,’ a high temperature alarm exists, it is now 50 degrees Fahrenheit, too high. Listen to sound for ten seconds.”

“Hello, this is 555-2278, ‘Acme Medical Laboratory,’ Zone One, ‘Temperature in Refrigerator One,’ a high temperature alarm exists, it is now 50 degrees Fahrenheit, too high. Listen to sound for ten seconds.”

“Enter acknowledgment code.”

2800 will now wait 10 seconds for a Touch-Tone acknowledgment code to be entered. After the last digit of the acknowledgment code has been received, the 2800 will respond by saying: “Alarm Acknowledged.” The alarm has been acknowledged and the unit will hang up. Once the alarm has been acknowledged, the dialout process stops.

If a Touch-Tone acknowledgment code is not received, the 2800 will offer you a second chance to enter it, responding with: “beep,” “error,” “Enter acknowledgment code.” If the acknowledgement code is still not received, then the 2800 will respond by saying: “beep,” “error,” “goodbye.” The alarm has not been acknowledged.

The 2800 will hang up and wait the programmed INTERCALL TIME before making the next phone call. During this time you may call the unit back from a Touch-Tone phone and the unit will give a voice report. Once you receive the complete report, enter the code to acknowledge the alarm.

NOTE: An alarm cannot be acknowledged using a pulse (rotary) telephone unless the *Callback Acknowledgment* feature is enabled.

Alarm Acknowledgment—Numeric Pager Dialout

The 2800 will dial out to your pager service and leave a number on the display of your beeper. (See *Chapter Five*) The unit will then hang up without speaking a voice message and wait for you to call back and enter an acknowledgment code. This waiting period is called the INTERCALL TIME. During this time you may call the unit back from a Touch-Tone phone to receive a report of the alarm condition and acknowledge the alarm by entering the acknowledgment code.

NOTE: An alarm cannot be acknowledged using a pulse (rotary) telephone unless the *Callback Acknowledgment* feature is enabled.

Below is an example of what the 2800 will say when you call it back to acknowledge a typical alarm:

“Hello, this is 555-2278, ‘Acme Medical Laboratory,’ Zone One, ‘Temperature in Refrigerator One,’ a high temperature alarm exists, it is now 50 degrees Fahrenheit, too high. Listen to sound for ten seconds.”

“Enter acknowledgment code.”

The 2800 will now wait 10 seconds for a Touch-Tone acknowledgment code to be entered. After the last digit of the acknowledgment code has been received, the 2800 will respond by saying: “Alarm Acknowledged.” The alarm has been acknowledged and the unit will hang up. Once the alarm has been acknowledged, the dialout process stops.

If a Touch-Tone acknowledgment code is not received, the 2800 will offer you a second chance to enter it, responding with: “beep,” “error,” “Enter acknowledgment code.” If an acknowledgement code is still not received, then the 2800 will respond by saying: “beep,” “error,” “goodbye.” The alarm has not been acknowledged. The 2800 will hang up and wait for you to call back and enter the acknowledgment code. This waiting period is called the INTERCALL TIME. During this time you may call the unit back from a Touch-Tone phone and the unit will give a voice report. Once you receive the complete report, enter the code to acknowledge the alarm.

NOTE: An alarm cannot be acknowledged using a pulse (rotary) telephone unless the *Callback Acknowledgment* feature is enabled.

TIP: When the 2800 is programmed to make calls to pagers, make sure the intercall delay time is long enough to give the person carrying the pager some time to get to a phone to call the unit back.

Alarm Acknowledgment—Automatic (Max Calls)

The 2800 has the ability to acknowledge itself by using the Max Calls function. The unit keeps a count of the number of phone calls it makes for a particular alarm. Once the number of calls made reaches Max Calls, the 2800 will acknowledge the alarm and stop the dialout process. The default setting for Max Calls is 100.

Wireless Sensor Diagnostic Alarms

The Sensaphone 2800 will monitor wireless sensor communications and battery status. If sensor communications are disrupted or if a sensor battery becomes low, the 2800 will dial out and notify you of the problem. Low battery alarms will occur when the batteries reach 1.1 volt per cell. In addition, a low battery message will be added to the status report for the sensor in question. A sensor communications alarm will occur if a sensor fails to communicate with the 2800 for a specified period of time.

CALL-IN STATUS

You can also call into the 2800 using a Touch-Tone telephone to obtain a status report. After answering, the 2800 will recite a status report. Immediately following the status report, the 2800 allows you to use Touch-Tone commands to enable/disable zones, change limits, control the output, etc. See the next section, Remote Commands via Touch-Tone Phone.

Below is an example of a voice status report:

“Hello, this is 555-2278, ‘Acme Medical Laboratory’

“Zone one, ‘Temperature in refrigerator one,’ 38 degrees Fahrenheit, OK

“Zone two, ‘Temperature in refrigerator two,’ 40 degrees Fahrenheit, OK

“Zone three, ‘Water pressure monitor,’ OK

“Zone four, ‘Nitrogen gas tank level in percent,’ 15, too low, acknowledged alarm exists

Wireless sensor five, ‘room humidity’, 45, OK

Wireless sensor six, ‘water detector’, OK

Wireless sensor seven, ‘motion detector’, OK

Wireless sensor eight, ‘ups alarm’, OK

“The Sound is OK”

“The Power is ON”

“The Battery is OK”

“The Output is off”

“Listen to the sound for 10 seconds”

“Good-Bye”

REMOTE COMMANDS VIA TOUCH-TONE PHONE

You can issue a number of commands to the 2800 remotely using a Touch-Tone telephone. This command mode can be entered at any time during the status report. Simply press a Touch-Tone and the unit will halt the report and respond with “OK.” You are now in Touch-Tone command mode. Commands are available to perform the following functions:

- Enable and disable zones, power monitoring, and sound monitoring
- Recite/Set High and Low alarm limits
- Recite/Set telephone numbers
- Record/Play custom voice messages
- Recite/Set the relay output
- Activate the microphone for listen-in
- Recite status report
- Recite alarm history

The commands are put together based on the letters of a touch-tone telephone. See typical telephone keypad layout below.



Figure 1: A telephone keypad

Many of the commands use three letters that represent an abbreviation of the selected command. For example, to Set a High limit on Zone 1 you would press S + H + 1 (or in numeric form 7 + 4 + 1)

The tables below list all of the touch-tone commands that are supported. Commands are listed in both character and numeric formats. The # key is used as an ENTER key. Use the * key to represent a negative sign or to represent the [CODE] key when programming telephone numbers.

Enable/Disable Zones

This command will toggle the selected zone between the enabled or disabled state.

<u>Description</u>	<u>Touch-Tone Command</u>
Enable/Disable Zone	* + Z(0) + (zone number)

Set and Recite High & Low Alarm Limits

The following commands are used to set or recite the Low Alarm Limit for any Zone.

<u>Description</u>	<u>Touch-Tone Command</u>
Set Zone Low Limit	S(7) + L(5) + (zone number) + (value) + #

<u>Description</u>	<u>Touch-Tone Command</u>
What Is Zone Low Limit	W(9) + L(5) + (zone number) + (value)+ #

The following commands are used to set or recite the High Alarm Limit for any Zone.

<u>Description</u>	<u>Touch-Tone Command</u>
Set Zone High Limit	S(7) + H(4) + (zone number) + (value)+ #

<u>Description</u>	<u>Touch-Tone Command</u>
What Is Zone High Limit	W(9) + H(4) + (zone number) + (value)+ #

Set and Recite Telephone Numbers

The following commands will allow you to program and recite dialout telephone numbers. You may need to use the Special Dialing Codes below.

Special Dialing Codes Summary

- Code 1: Numeric pager type
- Code 2: Wait for answer
- Code 3: Change to Touch-Tone
- Code 4: Pause
- Code 5: *
- Code 6: #

<u>Description</u>	<u>Touch-Tone Command</u>
Setting a phone number	S(7) + T(8) + (entry 1–8) + (telephone number) + #

<u>Description</u>	<u>Touch-Tone Command</u>
Reciting a phone number	W(9) + T(8) + (entry 1–8)

Record and Play Custom Voice Messages

The following commands will allow you to record and play back custom voice messages for the ID message (0) and each zone (1–8).

<u>Description</u>	<u>Touch-Tone Command</u>
Record a Message	S(7) + M(6) + (entry 0–8)

<u>Description</u>	<u>Touch-Tone Command</u>
Play a Message	W(9) + M(6) + (entry 0–8)

Control the Relay Output

The following commands will allow you to check the status of the relay output and to toggle the Relay Output On and Off.

<u>Description</u>	<u>Touch-Tone Command</u>
Reciting the Output Status	W(9) + R(7) + O(6)

<u>Description</u>	<u>Touch-Tone Command</u>
Switching the Output	S(7) + R(7) + O(6)

Activate Microphone Listen-in

The following command will allow you to activate the microphone listen-in for the programmed duration.

<u>Description</u>	<u>Touch-Tone Command</u>
Activate Mic Listen-in	M(6) + I(4) + C(2)

Request Status Report

The following command will initiate a status report.

<u>Description</u>	<u>Touch-Tone Command</u>
Recite status report	W(9) + S(7) + R(7)

Request Alarm History

The following command will recite the alarm history.

<u>Description</u>	<u>Touch-Tone Command</u>
Recite alarm history	H(4) + I(4) + S(7)

Hang-up

The following command will make the 2800 hang up the telephone line.

<u>Description</u>	<u>Touch-Tone Command</u>
Hang-up the phone line	B(2) + Y(9) + E(3)

NOTE: If a security code is enabled, the 2800 will prompt you with “Enter security code.” Enter the four-digit keypad security code plus “#” to enter touch-tone command mode. If entered correctly, the

2800 will respond with “OK” and you can proceed to enter the commands. If entered incorrectly, the unit will give you one more chance. If it is incorrect a second time, the unit will say “Error, goodbye” and hang up.

CHAPTER 8: WIRELESS SENSORS

WSR-0100 WIRELESS INDOOR TEMPERATURE SENSOR

INTRODUCTION

The WSR-0100 Wireless Indoor Temperature sensor is designed to work with the Sensaphone 2800 Environmental Monitoring System. This sensor includes a built-in radio transmitter and temperature element for monitoring temperature wherever the device is installed. You can also remove the internal temperature element and connect a remote temperature probe so that measurements can be made in a refrigerator/freezer or other harsh environment. The sensor comes with 3 AAA alkaline batteries which will power the sensor for up to 3 years. An optional plug-in power supply is also available in which case the batteries become a backup if main AC power fails.



NOTE: Do not install the entire sensor housing in a dirty, humid, or corrosive environment. Do not install the sensor in close proximity to other 2.4GHz devices (WiFi etc) .Do not install the device inside of a metallic enclosure as this will impede it's ability to wirelessly communicate with the Sensaphone 2800 unit.

Package Contents

- (1) WSR-0100 Wireless Indoor Temperature Sensor
- (3) AAA Alkaline batteries
- (2) Plastic drywall anchors
- (2) #6 Metal tapping screws
- (1) 1/16" hex key

MOUNTING

The temperature sensor can be mounted directly on a flat surface or attached to a plastic single-gang electrical outlet box. Consideration should be given as to whether or not an electrical outlet will be required if using the optional power supply. Mount the sensor as high as possible to provide for optimal wireless transmission. When installed within a building where the wireless signal must travel through several obstructions, the sensor should be located within 100' of the Sensaphone 2800 or within 100' of a repeater. If the sensor has line-of-sight with the Sensaphone 2800 (or a repeater), then it may be located up to 300' away.

Electrical box installation

Using the hex key remove the sensor cover by turning the two hex screws located on the bottom of the sensor housing clockwise. Carefully lift off the cover. Attach the sensor housing to the electrical box using the appropriate screws.

Surface installation

Remove the sensor cover by turning the two hex screws on the bottom of the sensor housing clockwise. Use a pencil to mark the hole locations at the top and bottom of the housing. Remove the sensor from the wall. Install the drywall anchors (if necessary) to the wall. Attach the sensor housing to the wall using #6 tapping screws.

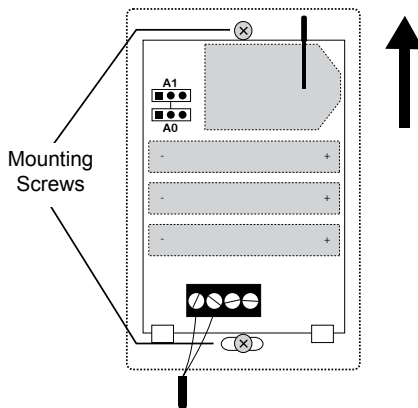

CHANNEL SELECTION

The Sensaphone 2800 and associated sensors must be set to operate on the same wireless channel. There are four possible channels. If you will be installing more than one 2800 unit in the same area you must configure each system on its own channel. By default the 2800 and sensors are set to channel one. To change the channel on the sensor, remove the cover using the hex key. Turn the hex screws clockwise until the cover easily slides off. Next, locate the jumpers on the circuit board as shown in the figure below. Remove all power from the sensor by taking out the alkaline batteries and unplugging the power supply (if used). The table shows how to configure the jumpers for a particular channel.

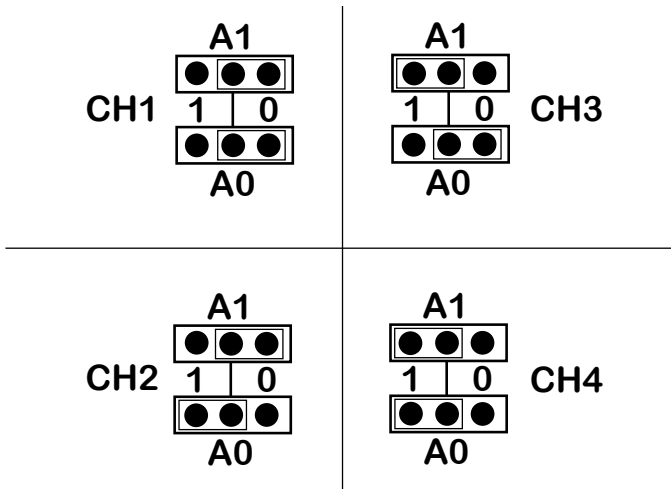

BATTERY INSTALLATION

The Wireless Indoor Temperature Sensor can operate for up to 3 years on a set of AAA alkaline batteries. The Sensaphone 2800 will notify you when the batteries are starting to get low. If you prefer you can install the optional plug-in power supply and use the batteries as a back-up in the event of an AC power failure. Install the 3 AAA batteries as shown below:

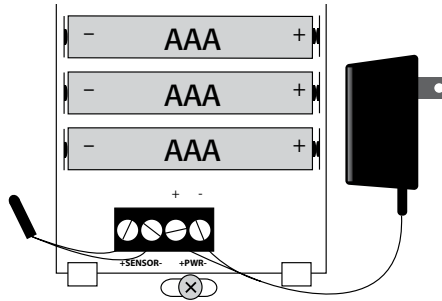

If you will be installing the optional 5V power supply, connect the wire marked “+” to the “+” screw terminal and connect the wire marked “-” to the “-” terminal on the PWR terminal strip. Next, plug-in the adapter.

After you have configured the channel, installed the AAA batteries and/or connected the AC power supply, replace the cover and secure it by turning the two hex screws on the bottom of the cover counterclockwise.

BATTERY INFORMATION

The projected battery life is dependent upon many factors including: rated capacity of battery, state of charge, temperature, and sensor distance from the 2800 (or repeater). The farther a sensor is from its receiver the more power it will require to transmit its signal, thus reducing battery life. Higher temperatures will also decrease battery life. Always use high quality alkaline batteries in Sensaphone 2800 series wireless sensors. Remove the batteries from the sensor if you will be taking it out of service for a period of time.

NOTE: If the sensor has only batteries installed and it is not configured for communication with the 2800, it will consume maximum power trying to establish communication and result in premature battery failure.

COMMUNICATING WITH THE 2800

The sensor will communicate with the Sensaphone 2800 every 20 seconds. As a result, alarm detection at the 2800 may be delayed. See chapter 4 for information on setting the wireless channel in the 2800 and for adding a sensor.

REPLACING THE TEMPERATURE ELEMENT

The internal temperature element (2.8K thermistor) can be replaced with an external probe for monitoring temperature within a refrigerator/freezer or other harsh environment. Sensaphone part # FGD-0101 is a weatherproof temperature probe that is ideally suited for this purpose. Before installing the probe you may want to disable the corresponding input channel on the 2800 to prevent an alarm from occurring while changing the probe. To install the probe, remove the sensor cover and loosen the sensor screw terminals and remove the thermistor. Next, connect the wires from the weatherproof probe to the terminal strip. There is no polarity for temperature sensors. Reattach the sensor cover and re-enable the input on the 2800.

SPECIFICATIONS

Operating Temperature Range: 32° to 122° F (0° to 50° C)

Monitoring Temperature Range: -109° to 115° F (-85° to 57° C) - (requires external probe to exceed operating limits)

Operating Humidity: 5- 90% RH non-condensing

Sensor Type: 2.8K thermistor

Accuracy: +/- 3° F

Range (Indoor/Urban): Up to 100' (30m)

Range (Line-of-sight): Up to 300' (100m)

Transmit Power Output: 1mW (0dBm)

Operating Frequency: ISM 2.4 GHz

Power: (3) AAA alkaline batteries and/or 5VDC (300mA) plug-in adapter

Battery Life: Approximately 3 years

Dimensions: 4 1/2 " x 2 3/4" x 1 1/4"

Housing: White plastic

*Specifications subject to change without notice

WSR-0101 WIRELESS INDOOR DRY CONTACT SENSOR

INTRODUCTION

The WSR-0101 Wireless Indoor Dry Contact sensor is designed to work with the Sensaphone 2800 Environmental Monitoring System. This sensor includes a built-in radio transmitter and input terminals for connecting to any normally-open or normally closed output. (Use of this device with solid-state outputs is not recommended.) The sensor comes with 3 AAA alkaline alkaline batteries which will power the sensor for up to 3 years. An optional plug-in power supply is also available in which case the batteries become a backup if main AC power fails.



NOTE: Do not install the entire sensor housing in a dirty, humid, or corrosive environment. Do not install the sensor in close proximity to other 2.4GHz devices (WiFi etc). Do not install the device inside of a metallic enclosure as this will impede it's ability to wirelessly communicate with the Sensaphone 2800 unit.

Package Contents

- (1) WSR-0101 Wireless Indoor Dry Contact Sensor
- (3) AAA Alkaline batteries
- (2) Plastic drywall anchors
- (2) #6 Metal tapping screws
- (1) 1/16" hex key

MOUNTING

The dry contact sensor can be mounted directly on a flat surface or attached to a plastic single-gang electrical outlet box. Consideration should be given as to whether or not an electrical outlet will be required if using the optional power supply. Mount the sensor as high as possible to provide for optimal wireless transmission. When installed within a building where the wireless signal must travel through several obstructions, the sensor should be located within 100' of the Sensaphone 2800 or within 100' of a repeater. If the sensor has line-of-sight with the Sensaphone 2800 (or a repeater), then it may be located up to 300' away.

Electrical box installation

Using the hex key remove the sensor cover by turning the two hex screws located on the bottom of the sensor housing clockwise. Carefully lift off the cover. Attach the sensor housing to the electrical box using the appropriate screws.

Surface installation

Remove the sensor cover by turning the two hex screws on the bottom of the sensor housing clockwise. Use a pencil to mark the hole locations at the top and bottom of the housing. Remove the sensor from the wall. Install the drywall anchors (if necessary) to the wall. Attach the sensor housing to the wall using #6 tapping screws.

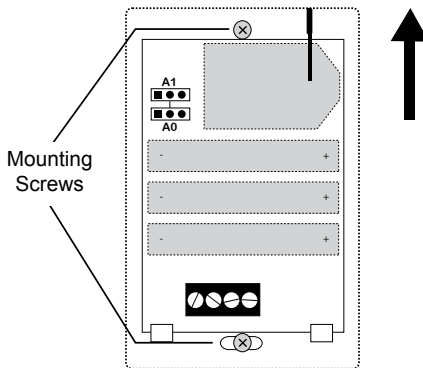

CHANNEL SELECTION

The Sensaphone 2800 and associated sensors must be set to operate on the same wireless channel. There are four possible channels. If you will be installing more than one 2800 unit in the same area you must configure each system on its own channel. By default the 2800 and sensors are set to channel one. To change the channel on the sensor, remove the cover using the hex key. Turn the hex screws clockwise until the cover easily slides off. Next, locate the jumpers on the circuit board as shown in the figure below. Remove all power from the sensor by taking out the alkaline batteries and unplugging the power supply (if used). The table shows how to configure the jumpers for a particular channel.

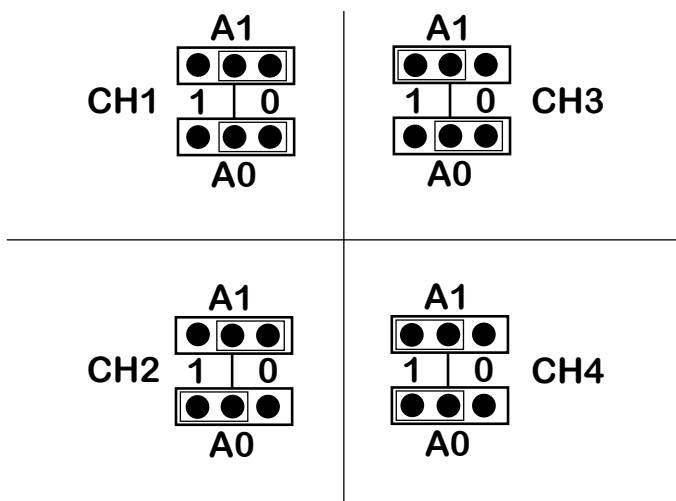

BATTERY INSTALLATION

The Wireless Indoor Dry Contact Sensor can operate for up to 3 years on a set of AAA alkaline batteries. The Sensaphone 2800 will notify you when the batteries are starting to get low. If you prefer you can install the optional plug-in power supply and use the batteries as a back-up in the event of an AC power failure. Install the 3 AAA batteries as shown below:

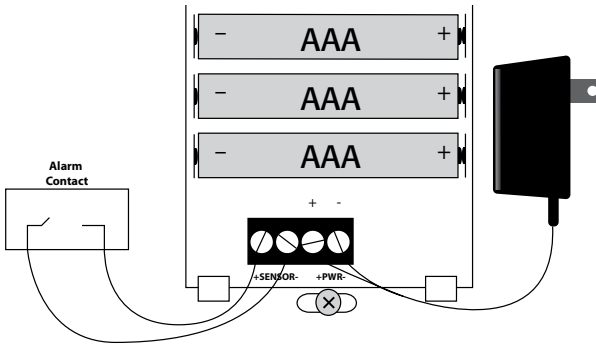

If you will be installing the optional 5V power supply, connect the wire marked “+” to the “+” screw terminal and connect the wire marked “-” to the “-” terminal on the PWR terminal strip. Next, plug-in the adapter.

After you have configured the channel, installed the AAA batteries and/or connected the AC power supply, replace the cover and secure it by turning the two hex screws on the bottom of the cover counterclockwise.

BATTERY INFORMATION

The projected battery life is dependent upon many factors including: rated capacity of battery, state of charge, temperature, and sensor distance from the 2800 (or repeater). The farther a sensor is from its receiver the more power it will require to transmit its signal, thus reducing battery life. Higher temperatures will also decrease battery life. Always use high quality alkaline batteries in Sensaphone 2800 series wireless sensors. Remove the batteries from the sensor if you will be taking it out of service for a period of time.

NOTE: If the sensor has only batteries installed and it is not configured for communication with the 2800, it will consume maximum power trying to establish communication and result in premature battery failure.

COMMUNICATING WITH THE 2800

The sensor will communicate with the Sensaphone 2800 every 20 seconds. See chapter 4 for information on setting the wireless channel in the 2800 and for adding a sensor.

SPECIFICATIONS

Operating Temperature Range: 32° to 122° F (0° to 50° C)

Operating Humidity: 5- 90% RH non-condensing

Input Characteristics: 3M Ω to 3V

Range (Indoor/Urban): Up to 100' (30m)

Range (Line-of-sight): Up to 300' (100m)

Transmit Power Output: 1mW (0dBm)

Operating Frequency: ISM 2.4 GHz

Power: (3) AAA alkaline batteries and/or 5VDC (300mA) plug-in adapter

Battery Life: Up to 3 years

Dimensions: 4 1/2 " x 2 3/4" x 1 1/4"

Housing: White plastic

*Specifications subject to change without notice

WSR-0102 WIRELESS POWER FAILURE SENSOR

INTRODUCTION

The WSR-0102 Wireless Indoor Power Failure sensor is designed to work with the Sensaphone 2800 Environmental Monitoring System. This sensor includes a built-in radio transmitter, AAA alkaline batteries and a wall plug in power supply. The sensor will detect a loss of power at the outlet where the power supply is attached. The 3 AAA alkaline batteries will power the sensor and allow it to transmit alarm information in the event that AC power fails.



NOTE: Do not install the entire sensor housing in a dirty, humid, or corrosive environment. Do not install the sensor in close proximity to other 2.4GHz devices (WiFi etc). Do not install the device inside of a metallic enclosure as this will impede it's ability to wirelessly communicate with the Sensaphone 2800 unit.

Package Contents

- (1) WSR-0102 Wireless Indoor Power Failure Sensor
- (3) AAA Alkaline batteries
- (2) Plastic drywall anchors
- (2) #6 Metal tapping screws
- (1) 1/16" hex key
- (1) DC power supply

MOUNTING

The power failure sensor can be mounted directly on a flat surface or attached to a plastic single-gang electrical outlet box. Make sure there is an electrical outlet nearby. Mount the sensor as high as possible to provide for optimal wireless transmission. When installed within a building where the wireless signal must travel through several obstructions, the sensor should be located within 100' of the Sensaphone 2800 or within 100' of a repeater. If the sensor has line-of-sight with the Sensaphone 2800 (or a repeater), then it may be located up to 300' away.

Electrical box installation

Using the hex key remove the sensor cover by turning the two hex screws located on the bottom of the sensor housing clockwise. Carefully lift off the cover. Attach the sensor housing to the electrical box using the appropriate screws.

Surface installation

Remove the sensor cover by turning the two hex screws on the bottom of the sensor housing clockwise. Use a pencil to mark the hole locations at the top and bottom of the housing. Remove the sensor from the wall. Install the drywall anchors (if necessary) to the wall. Attach the sensor housing to the wall using #6 tapping screws.

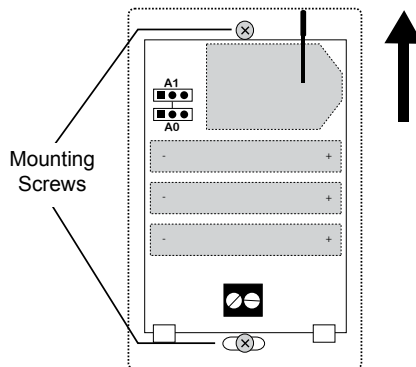

CHANNEL SELECTION

The Sensaphone 2800 and associated sensors must be set to operate on the same wireless channel. There are four possible channels. If you will be installing more than one 2800 unit in the same area you must configure each system on its own channel. By default the 2800 and sensors are set to channel one. To change the channel on the sensor, remove the cover using the hex key. Turn the hex screws clockwise until the cover easily slides off. Next, locate the jumpers on the circuit board as shown in the figure below. Remove all power from the sensor by taking out the alkaline batteries and unplugging the power supply. The table shows how to configure the jumpers for a particular channel.

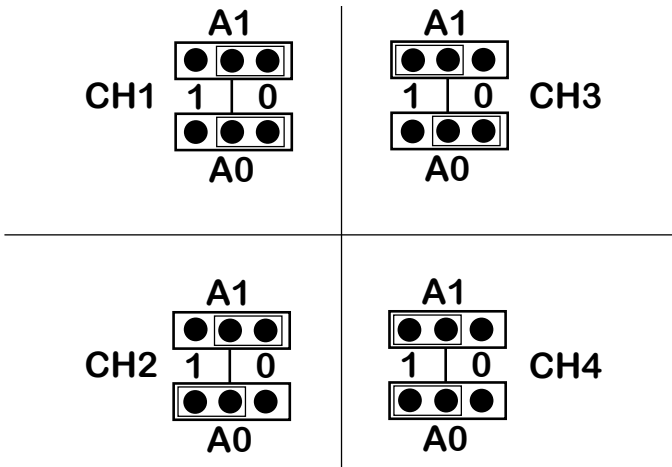

BATTERY INSTALLATION

The sensor uses the wall plug-in power supply to both sense the presence of power and also to power the device, so that it can communicate with the 2800. The alkaline batteries are used to power the device when main AC power fails. As a result, the batteries will likely last for several years, however they should still be replaced after a few years to insure that they will be able to power the device when needed.

Wire the power supply to the sensor before you plug it in. Connect the wire marked “+” to the “+” screw terminal and connect the wire marked “-” to the “-” terminal on the PWR terminal strip. Plug the power supply into the outlet you want to monitor. Next, install the AAA alkaline batteries. See figure below:

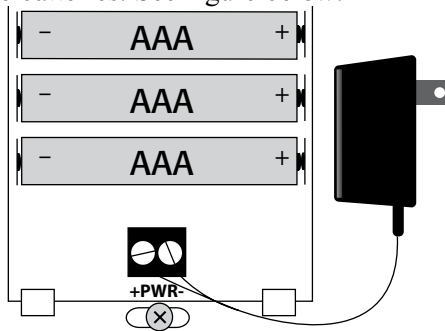

After you have configured the channel, installed the AAA batteries and connected the power supply, replace the cover and secure it by turning the two hex screws on the bottom of the cover counterclockwise.

BATTERY INFORMATION

The projected battery life is dependent upon many factors including: rated capacity of battery, state of charge, temperature, and sensor distance from the 2800 (or repeater). The farther a sensor is from its receiver the more power it will require to transmit its signal, thus reducing battery life. Higher temperatures will also decrease battery life. Always use high quality alkaline batteries in Sensaphone 2800 series wireless sensors. Remove the batteries from the sensor if you will be taking it out of service for a period of time.

NOTE: If the sensor has only batteries installed and it is not configured for communication with the 2800, it will consume maximum power trying to establish communication and result in premature battery failure.

COMMUNICATING WITH THE 2800

The sensor will communicate with the Sensaphone 2800 every 20 seconds. See chapter 4 for information on setting the wireless channel in the 2800 and for adding a sensor.

SPECIFICATIONS

Operating Temperature Range: 32° to 122° F (0° to 50° C)

Operating Humidity: 5- 90% RH non-condensing

Range (Indoor/Urban): Up to 100' (30m)

Range (Line-of-sight): Up to 300' (100m)

Transmit Power Output: 1mW (0dBm)

Operating Frequency: ISM 2.4 GHz

Power: (3) AAA alkaline batteries and 5VDC (300mA) plug-in adapter

Battery Life: Up to 3 years

Dimensions: 4 1/2 " x 2 3/4" x 1 1/4"

Housing: White plastic

*Specifications subject to change without notice

WSR-0103 WIRELESS INDOOR HUMIDITY SENSOR

INTRODUCTION

The WSR-0103 Wireless Indoor Humidity sensor is designed to work with the Sensaphone 2800 Environmental Monitoring System. This sensor includes a built-in radio transmitter and humidity sensor element for monitoring humidity wherever the device is installed. The sensor comes with 3 AAA alkaline batteries which will power the sensor for up to 3 years. An optional plug-in power supply is also available in which case the batteries become a backup if main AC power fails.



NOTE: Do not install the entire sensor housing in a dirty or corrosive environment. Do not install the sensor in close proximity to other 2.4GHz devices (WiFi etc). Do not install the device inside of a metallic enclosure as this will impede it's ability to wirelessly communicate with the Sensaphone 2800 unit.

Package Contents

- (1) WSR-0103 Wireless Indoor Humidity Sensor
- (3) AAA Alkaline batteries
- (2) Plastic drywall anchors
- (2) #6 Metal tapping screws
- (1) 1/16" hex key

MOUNTING

The humidity sensor can be mounted directly on a flat surface or attached to a plastic single-gang electrical outlet box. Consideration should be given as to whether or not an electrical outlet will be required if using the optional power supply. Mount the sensor as high as possible to provide for optimal wireless transmission. When installed within a building where the wireless signal must travel through several obstructions, the sensor should be located within 100' of the Sensaphone 2800 or within 100' of a repeater. If the sensor has line-of-sight with the Sensaphone 2800 (or a repeater), then it may be located up to 300' away.

Electrical box installation

Using the hex key remove the sensor cover by turning the two hex screws located on the bottom of the sensor housing clockwise. Carefully lift off the cover. Attach the sensor housing to the electrical box using the appropriate screws.

Surface installation

Remove the sensor cover by turning the two hex screws on the bottom of the sensor housing clockwise. Use a pencil to mark the hole locations at the top and bottom of the housing. Remove the sensor from the wall. Install the drywall anchors (if necessary) to the wall. Attach the sensor housing to the wall using #6 tapping screws.

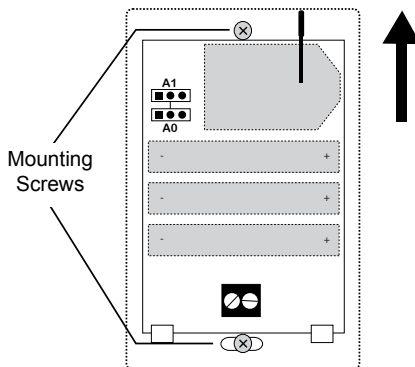

CHANNEL SELECTION

The Sensaphone 2800 and associated sensors must be set to operate on the same wireless channel. There are four possible channels. If you will be installing more than one 2800 unit in the same area you must configure each system on its own channel. By default the 2800 and sensors are set to channel one. To change the channel on the sensor, remove the cover using the hex key. Turn the hex screws clockwise until the cover easily slides off. Next, locate the jumpers on the circuit board as shown in the figure below. Remove all power from the sensor by taking out the alkaline batteries and unplugging the power supply (if used). The table shows how to configure the jumpers for a particular channel.

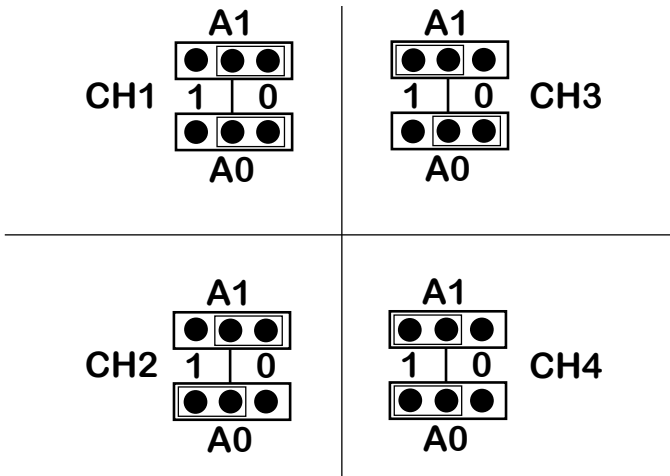

BATTERY INSTALLATION

The Wireless Indoor Humidity Sensor can operate for up to 3 years on a set of AAA alkaline batteries. The Sensaphone 2800 will notify you when the batteries are starting to get low. If you prefer you can install the optional plug-in power supply and use the batteries as a back-up in the event of an AC power failure. Install the 3 AAA batteries as shown below:

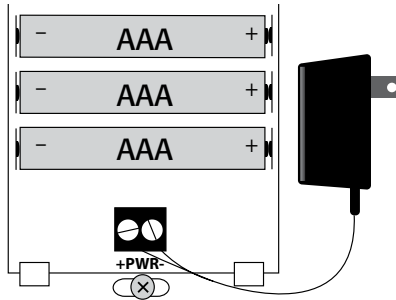

If you will be installing the optional 5V power supply, connect the wire marked “+” to the “+” screw terminal and connect the wire marked “-” to the “-” terminal on the PWR terminal strip. Next, plug-in the adapter.

After you have configured the channel, installed the AAA batteries and/or connected the AC power supply, replace the cover and secure it by turning the two hex screws on the bottom of the cover counterclockwise.

BATTERY INFORMATION

The projected battery life is dependent upon many factors including: rated capacity of battery, state of charge, temperature, and sensor distance from the 2800 (or repeater). The farther a sensor is from its receiver the more power it will require to transmit its signal, thus reducing battery life. Higher temperatures will also decrease battery life. Always use high quality alkaline batteries in Sensaphone 2800 series wireless sensors. Remove the batteries from the sensor if you will be taking it out of service for a period of time.

NOTE: If the sensor has only batteries installed and it is not configured for communication with the 2800, it will consume

maximum power trying to establish communication and result in premature battery failure.

COMMUNICATING WITH THE 2800

The sensor will communicate with the Sensaphone 2800 every 20 seconds. See chapter 4 for information on setting the wireless channel in the 2800 and for adding a sensor.

SPECIFICATIONS

Operating Temperature Range: 32° to 122° F (0° to 50° C)

Operating Humidity Range: 0- 95% RH non-condensing

Accuracy: +/- 3% from 20-80% RH ($\pm 5\%$ otherwise)

Range (Indoor/Urban): Up to 100' (30m)

Range (Line-of-sight): Up to 300' (100m)

Transmit Power Output: 1mW (0dBm)

Operating Frequency: ISM 2.4 GHz

Power: (3) AAA alkaline batteries and/or 5VDC (300mA) plug-in adapter

Battery Life: Up to 3 years

Dimensions: 4 1/2 " x 2 3/4" x 1 1/4"

Housing: White plastic

*Specifications subject to change without notice

WSR-0104 WIRELESS INDOOR 4-20mA SENSOR

INTRODUCTION

The WSR-0104 Wireless Indoor 4-20mA sensor is designed to work with the Sensaphone 2800 Environmental Monitoring System. This sensor includes a built-in radio transmitter, 4-20mA input and a 24V loop power supply. The sensor can be used to monitor the output of any 4-20mA transducer. The sensor comes with a plug-in power supply and 3 AAA alkaline batteries which will power the sensor for several hours if main AC power fails.



NOTE: Do not install the entire sensor housing in a dirty, humid, or corrosive environment. Do not install the sensor in close proximity to other 2.4GHz devices (WiFi etc). Do not install the device inside of a metallic enclosure as this will impede it's ability to wirelessly communicate with the Sensaphone 2800 unit.

Package Contents

- (1) WSR-0104 Wireless Indoor 4-20mA Sensor
- (3) AAA Alkaline batteries
- (2) Plastic drywall anchors
- (2) #6 Metal tapping screws
- (1) 1/16" hex key
- (1) DC power supply

MOUNTING

The 4-20mA sensor can be mounted directly on a flat surface or attached to a plastic single-gang electrical outlet box. Make sure there is an electrical outlet nearby. Mount the sensor as high as possible to provide for optimal wireless transmission. When installed within a building where the wireless signal must travel through several obstructions, the sensor should be located within 100' of the Sensaphone 2800 or within 100' of a repeater. If the sensor has line-of-sight with the Sensaphone 2800 (or a repeater), then it may be located up to 300' away.

Electrical box installation

Using the hex key remove the sensor cover by turning the two hex screws located on the bottom of the sensor housing clockwise. Carefully lift off the cover. Attach the sensor housing to the electrical box using the appropriate screws.

Surface installation

Remove the sensor cover by turning the two hex screws on the bottom of the sensor housing clockwise. Use a pencil to mark the hole locations at the top and bottom of the housing. Remove the sensor from the wall. Install the drywall anchors (if necessary) to the wall. Attach the sensor housing to the wall using #6 tapping screws.

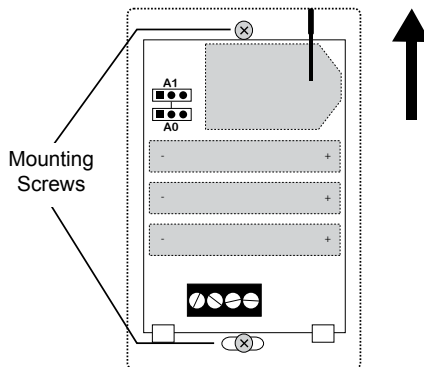

CHANNEL SELECTION

The Sensaphone 2800 and associated sensors must be set to operate on the same wireless channel. There are four possible channels. If you will be installing more than one 2800 unit in the same area you must configure each system on its own channel. By default the 2800 and sensors are set to channel one. To change the channel on the sensor, remove the cover using the hex key. Turn the hex screws clockwise until the cover easily slides off. Next, locate the jumpers on the circuit board as shown in the figure below. Remove all power from the sensor by taking out the alkaline batteries and unplugging the power supply. The table shows how to configure the jumpers for a particular channel.

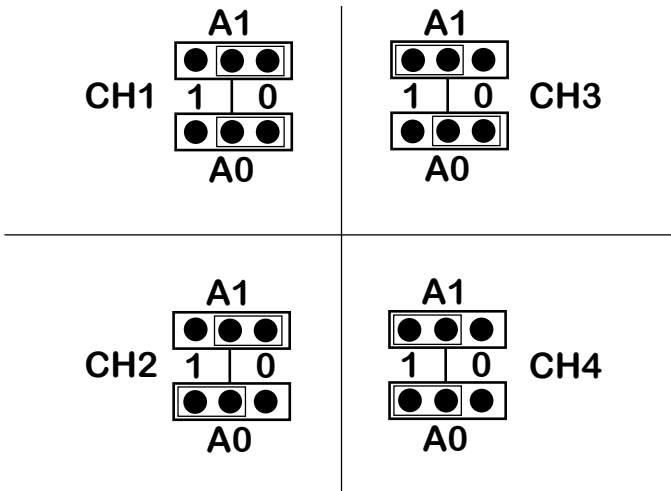

TRANSDUCER WIRING

The 4-20mA sensor includes a built-in 24V power supply which makes wiring your transducer easy. The 24V power appears at the Sensor + terminal. The Sensor - terminal is the signal input so all that is required is to connect your transducer directly to the Sensor + and - terminals as shown below:

POWER SUPPLY AND BATTERY INSTALLATION

The 4-20mA sensor is powered by a 5VDC plug-in power supply (included). Three AAA alkaline batteries are used as a back-up in the event of an AC power failure. The battery back-up time is totally dependent upon the average current in the loop - approximately three to six hours.

Connect the power supply wires to the PWR terminals. Connect the wire marked “+” to the “+” screw terminal and connect the “-” wire to the “-” terminal on the PWR terminal strip. Plug-in the power supply. Install the 3 AAA alkaline batteries as shown:

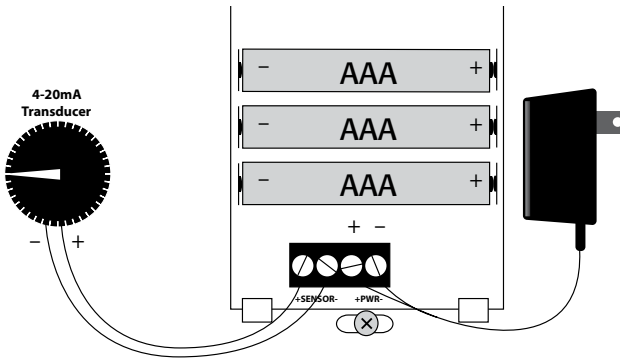

After you have configured the channel, installed the AAA batteries and/or connected the AC power supply, replace the cover and secure it by turning the two hex screws on the bottom of the cover counterclockwise.

BATTERY INFORMATION

The projected battery life is dependent upon many factors including: rated capacity of battery, state of charge, temperature, and sensor distance from the 2800 (or repeater). The farther a sensor is from its receiver the more power it will require to transmit its signal, thus reducing battery life. Higher temperatures will also decrease battery life. Always use high quality alkaline batteries in Sensaphone 2800

series wireless sensors. Remove the batteries from the sensor if you will be taking it out of service for a period of time.

NOTE: If the sensor has only batteries installed and it is not configured for communication with the 2800, it will consume maximum power trying to establish communication and result in premature battery failure.

COMMUNICATING WITH THE 2800

The sensor will communicate with the Sensaphone 2800 every 20 seconds. See chapter 4 for information on setting the wireless channel in the 2800 and for adding a sensor.

SPECIFICATIONS

Operating Temperature Range: 32° to 122° F (0° to 50° C)

Operating Humidity Range: 5- 90% RH non-condensing

Input Load: 260 Ohms

Accuracy: +/- 1%

Loop Current: 20mA max (24V)

Range (Indoor/Urban): Up to 100' (30m)

Range (Line-of-sight): Up to 300' (100m)

Transmit Power Output: 1mW (0dBm)

Operating Frequency: ISM 2.4 GHz

Power: (3) AAA alkaline batteries and 5VDC (300mA) plug-in adapter

Battery Life: 3-6 hours depending on loop current

Dimensions: 4 1/2 " x 2 3/4" x 1 1/4"

Housing: White plastic

*Specifications subject to change without notice

WSR-0105 WIRELESS MOTION DETECTOR

Introduction

The WSR-0105 Wireless Motion Detector is designed to work with the Sensaphone 2800 Environmental Monitoring System. This sensor includes a built-in radio transmitter, and three AA alkaline batteries to power the device. The batteries will provide up to three years of service. The device will detect motion of heat sources using infrared sensing technology and transmit this information to the Sensaphone 2800 using wireless technology.



NOTE: Do not install the entire sensor housing in a dirty, humid, or corrosive environment. Do not install the sensor in close proximity to other 2.4GHz devices (WiFi etc).

Package Contents

- (1) WSR-0105 Wireless Motion Detector
- (3) AA Alkaline batteries
- (2) Plastic drywall anchors
- (2) #6 Metal tapping screws

MOUNTING

1. Remove front cover from sensor by placing a flathead screwdriver in slot located on side of sensor, then rotate the screwdriver.

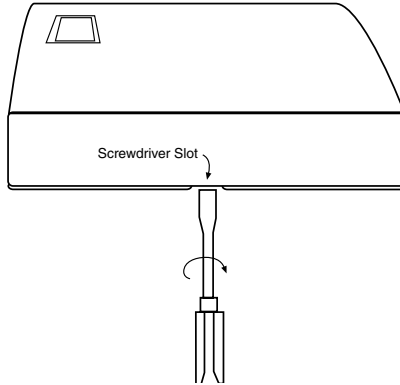

Figure 1

Warning: Do not face sensor toward the sun with the cover off. This will damage the sensor.

2. Carefully remove the board from the pegs before attempting to screw the back plate to the wall.

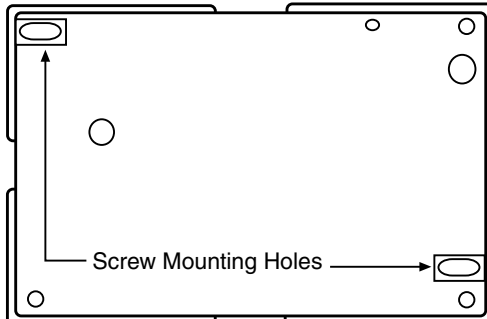

Figure 2

3. Mount the back cover to the wall, using the accompanying screws and the two knock-out slots for them in the back cover.

The sensor must be mounted with the long dimension parallel to the floor and ceiling, with the sensor's window to the left, not up. The detector can be mounted in either a surface wall mount position

(Figure 3) or in a corner mount position (Figure 4). Recommended (most effective) mounting height is 4.5 feet.

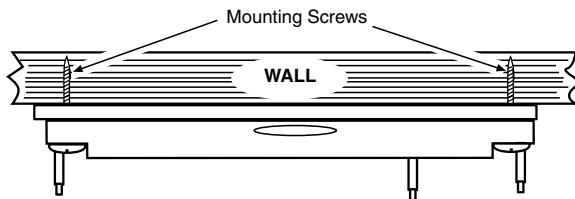

Figure 3: Surface mounting the Sensor

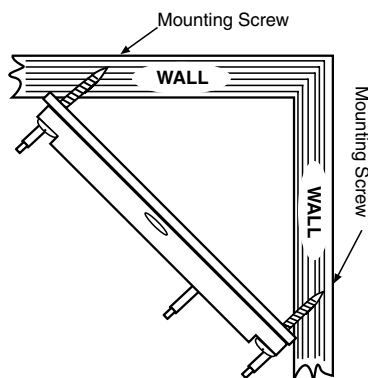
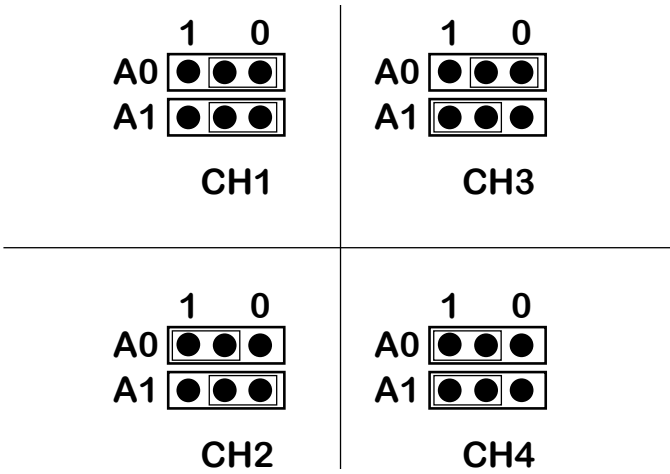

Figure 4: Corner Mounting the Sensor

CHANNEL SELECTION

The Sensaphone 2800 and associated sensors must be set to operate on the same wireless channel. There are four possible channels. If you will be installing more than one 2800 unit in the same area you must configure each system on its own channel. By default the 2800 and sensors are set to channel one. Locate the jumpers on the circuit board as shown in the figure below. Remove all power from the sensor by taking out the alkaline batteries. The table shows how to configure the jumpers for a particular channel.



BATTERY INSTALLATION

The Wireless Motion Detector can operate for up to 3 years on a set of AA alkaline batteries. The Sensaphone 2800 will notify you when the batteries are starting to get low. Always use Alkaline type batteries in this device. Install the batteries as shown in the diagram below, then replace the cover:

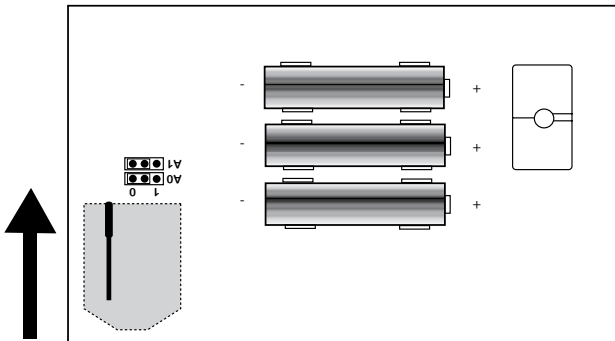

BATTERY INFORMATION

The projected battery life is dependent upon many factors including: rated capacity of battery, state of charge, temperature, and sensor distance from the 2800 (or repeater). The farther a sensor is from its receiver the more power it will require to transmit its signal, thus reducing battery life. Higher temperatures will also decrease battery life. Always use high quality alkaline batteries in Sensaphone 2800 series wireless sensors. Remove the batteries from the sensor if you will be taking it out of service for a period of time.

NOTE: If the sensor has only batteries installed and it is not configured for communication with the 2800, it will consume maximum power trying to establish communication and result in premature battery failure.

COMMUNICATING WITH THE 2800

The sensor will communicate with the Sensaphone 2800 every 20 seconds. See chapter 4 for information on setting the wireless channel in the 2800 and for adding a sensor.

SPECIFICATIONS

Operating Temperature Range: 32° to 122° F (0° to 50° C)

Operating Humidity Range: 5- 90% RH non-condensing

Infrared Motion Detect Range: Approximately 40'

Range (Indoor/Urban): Up to 100' (30m)

Range (Line-of-sight): Up to 300' (100m)

Transmit Power Output: 1mW (0dBm)

Operating Frequency: ISM 2.4 GHz

Power: (3) AA alkaline batteries

Battery Life: 3 years

Dimensions: 6^{5/8}" x 4" x 1^{5/8}"

Housing: White plastic

*Specifications subject to change without notice

WSR-0106 WIRELESS SPOT WATER DETECTION SENSOR

INTRODUCTION

The WSR-0106 Wireless Spot Water Detection Sensor is designed to work with the Sensaphone 2800 Environmental Monitoring System. This sensor includes a built-in radio transmitter and



water sensing probes for monitoring for the presence of water at a particular location. The sensor comes with 3 AA alkaline batteries which will power the sensor for up to 3 years.

NOTE: Do not install the entire sensor housing in a dirty, humid, or corrosive environment. Do not install the sensor in close proximity to other 2.4GHz devices (WiFi etc).

Package Contents

- (1) WSR-0106 Wireless Spot Water Detection Sensor
- (3) AA Alkaline batteries

CHANNEL SELECTION

The Sensaphone 2800 and associated sensors must be set to operate on the same wireless channel. There are four possible channels. If you will be installing more than one 2800 unit in the same area you must configure each system on its own channel. By default the 2800 and sensors are set to channel one. To change the channel on the sensor, remove the cover by removing the four outer screws on the bottom of the enclosure. See Figure 1:

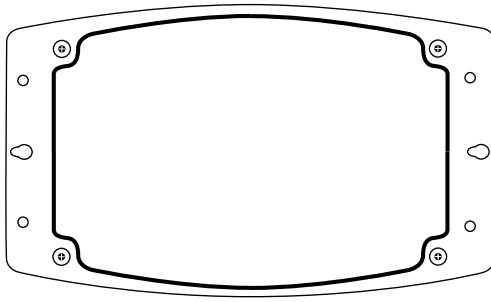

Figure 1

Next, locate the jumpers on the circuit board as shown in Figure 2.

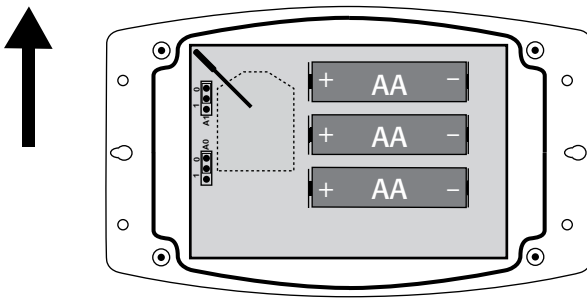

Figure 2

Remove all power from the sensor by taking out the batteries. Figure 3 shows how to configure the jumpers for a particular channel.

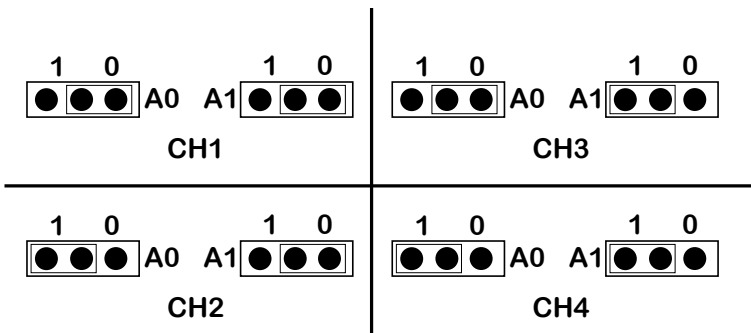

Figure 3

BATTERY INSTALLATION

After you have configured the channel, install the AA alkaline batteries (as shown in Figure 2), replace the cover and secure it by replacing the four screws on the bottom of the enclosure.

BATTERY INFORMATION

The projected battery life is dependent upon many factors including: rated capacity of battery, state of charge, temperature, and sensor distance from the 2800 (or repeater). The farther a sensor is from its receiver the more power it will require to transmit its signal, thus reducing battery life. Higher temperatures will also decrease battery life. Always use high quality alkaline batteries in Sensaphone 2800 series wireless sensors. Remove the batteries from the sensor if you will be taking it out of service for a period of time.

NOTE: If the sensor has only batteries installed and it is not configured for communication with the 2800, it will consume maximum power trying to establish communication and result in premature battery failure.

INSTALLATION

Place enclosure on the surface where the presence of water is to be monitored.

COMMUNICATING WITH THE 2800

The sensor will communicate with the Sensaphone 2800 every 20 seconds. See chapter 4 for information on setting the wireless channel in the 2800 and for adding a sensor.

SPECIFICATIONS

Operating Temperature Range: 32° to 122° F (0° to 50° C)

Operating Humidity Range: 0- 95% RH non-condensing

Range (Indoor/Urban): Up to 100' (30m)

Range (Line-of-sight): Up to 300' (100m)

Transmit Power Output: 1mW (0dBm)

Operating Frequency: ISM 2.4 GHz

Power: (3) AA alkaline batteries

Battery Life: up to 3 years

Dimensions: 5 1/2 “ x 3 3/8” x 1 3/8”

Housing: Light grey polycarbonate IP67/Nema 4x

*Specifications subject to change without notice

WSR-0107 WIRELESS ZONE WATER DETECTION SENSOR

INTRODUCTION

The WSR-0107 Wireless Zone Water Detection Sensor is designed to work with the Sensaphone 2800 Environmental Monitoring System. This sensor includes a built-in radio transmitter and ten feet of



water sensing cable for monitoring for the presence of water in a particular area. The size of the monitored area can be extended by attaching additional lengths of WaterRope (FGD-0063) to the end of the included WaterRope. You can connect up to ten lengths of WaterRope (100') to one Zone Water Detector. The sensor comes with 3 AA alkaline batteries which will power the sensor for up to 3 years.

NOTE: Do not install the entire sensor housing in a dirty, humid, or corrosive environment. Do not install the sensor in close proximity to other 2.4GHz devices (WiFi etc).

Package Contents

- (1) WSR-0107 Wireless Zone Water Detection Sensor
- (1) 10' WaterRope
- (5) Adhesive cable clamps
- (3) AA Alkaline batteries
- (2) Plastic drywall anchors
- (2) #6 metal tapping screws
- (4) Rubber feet

CHANNEL SELECTION

The Sensaphone 2800 and associated sensors must be set to operate on the same wireless channel. There are four possible channels. If you will be installing more than one 2800 unit in the same area you must configure each system on its own channel. By default the 2800 and sensors are set to channel one. To change the channel on the sensor, remove the cover by removing the four outer screws on the bottom of the enclosure. See Figure 1:

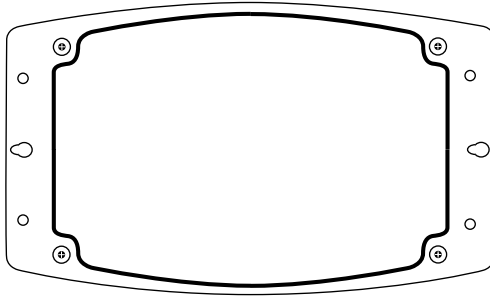

Figure 1

Next, locate the jumpers on the circuit board as shown in Figure 2.

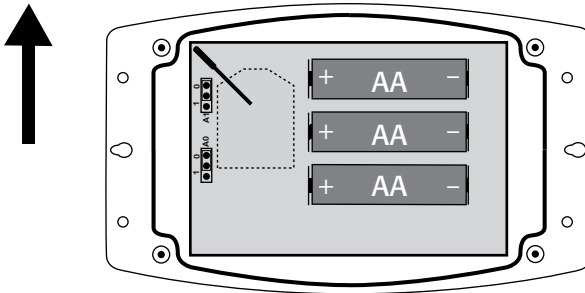

Figure 2

Remove all power from the sensor by taking out the batteries. Figure 3 shows how to configure the jumpers for a particular channel.

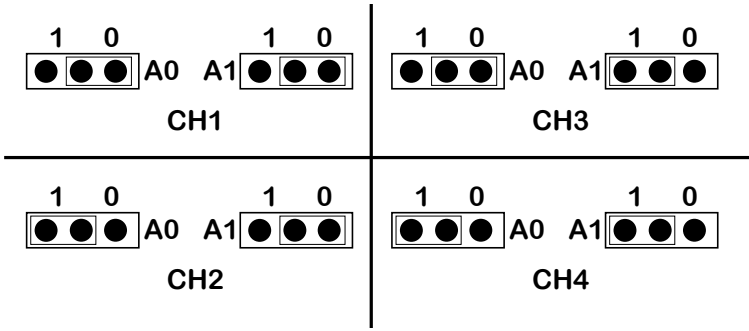

Figure 3

BATTERY INSTALLATION

After you have configured the channel, install the AA alkaline batteries (as shown in Figure 2), replace the cover and secure it by replacing the four screws on the bottom of the enclosure.

BATTERY INFORMATION

The projected battery life is dependent upon many factors including: rated capacity of battery, state of charge, temperature, and sensor distance from the 2800 (or repeater). The farther a sensor is from its receiver the more power it will require to transmit its signal, thus reducing battery life. Higher temperatures will also decrease battery life. Always use high quality alkaline batteries in Sensaphone 2800 series wireless sensors. Remove the batteries from the sensor if you will be taking it out of service for a period of time.

NOTE: If the sensor has only batteries installed and it is not configured for communication with the 2800, it will consume maximum power trying to establish communication and result in premature battery failure.

INSTALLATION

Mount the enclosure on a wall close to the area to be monitored. Connect the WaterRope to the connection on the side of the enclosure. Secure WaterRope to floor with self adhesive clamps.

COMMUNICATING WITH THE 2800

The sensor will communicate with the Sensaphone 2800 every 20 seconds. See chapter 4 for information on setting the wireless channel in the 2800 and for adding a sensor.

SPECIFICATIONS

Operating Temperature Range: 32° to 122° F (0° to 50° C)

Operating Humidity Range: 5- 95% RH non-condensing

Range (Indoor/Urban): Up to 100' (30m)

Range (Line-of-sight): Up to 300' (100m)

Transmit Power Output: 1mW (0dBm)

Operating Frequency: ISM 2.4 GHz

Power: (3) AA alkaline batteries

Battery Life: Up to 3 years

Dimensions: 5 1/2 " x 3 3/8" x 1 3/8"

Housing: Light grey polycarbonate

*Specifications subject to change without notice

WSR-0199 WIRELESS REPEATER

INTRODUCTION

The WSR-0199 Wireless Repeater is designed to work with the Sensaphone 2800 Environmental Monitoring System. The wireless repeater allows you to have greater distance between your wireless sensors and the Sensaphone 2800. It contains a more powerful radio transceiver which can transmit up to 300' indoors and up to 4,000' (line-of-sight). **Only one repeater can be used per Sensaphone 2800.** The sensor comes with a plug-in power supply and 3 AAA alkaline batteries for back-up in the event of an AC power failure.



NOTE: Do not install the entire sensor housing in a dirty, humid, or corrosive environment. Do not install the sensor in close proximity to other 2.4GHz devices (WiFi etc). Do not install the device inside of a metallic enclosure as this will impede it's ability to wirelessly communicate with the Sensaphone 2800 unit.

Package Contents

- (1) WSR-0199 Wireless Repeater
- (3) AAA Alkaline batteries
- (2) Plastic drywall anchors
- (2) #6 Metal tapping screws
- (1) 1/16" hex key
- (1) DC power supply

MOUNTING

The wireless repeater can be mounted directly on a flat surface or attached to a plastic single-gang electrical outlet box. Make sure there is an electrical outlet nearby. Mount the device as high as possible to provide for optimal wireless transmission. When installed within a building where the wireless signal must travel through several obstructions, the device should be located within 300' of the Sensaphone 2800 and within 100' of any sensors. If the repeater has line-of-sight with the Sensaphone 2800, then it may be located up to 4,000' away.

Electrical box installation

Using the hex key remove the repeater cover by turning the two hex screws located on the bottom of the sensor housing clockwise. Carefully lift off the cover. Attach the sensor housing to the electrical box using the appropriate screws.

Surface installation

Remove the repeater cover by turning the two hex screws on the bottom of the sensor housing clockwise. Use a pencil to mark the hole locations at the top and bottom of the housing. Remove the device from the wall. Install the drywall anchors (if necessary) to the wall. Attach the housing to the wall using #6 tapping screws.

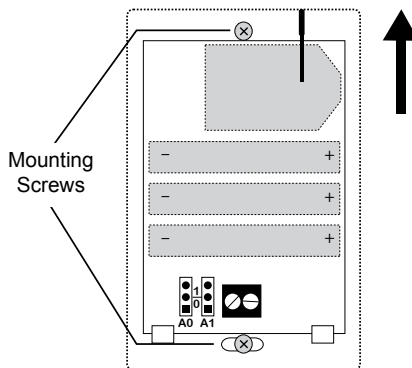

CHANNEL SELECTION

The Sensaphone 2800 and associated repeater must be set to operate on the same wireless channel. There are four possible channels. If you will be installing more than one 2800 unit in the same area you must configure each system on its own channel. By default the 2800 and repeater are set to channel one. To change the channel on the repeater, remove the cover using the hex key. Turn the hex screws clockwise until the cover easily slides off. Next, locate the jumpers on the circuit board as shown in the figure below. Remove all power from the device by taking out the alkaline batteries and unplugging the power supply. The table shows how to configure the jumpers for a particular channel.

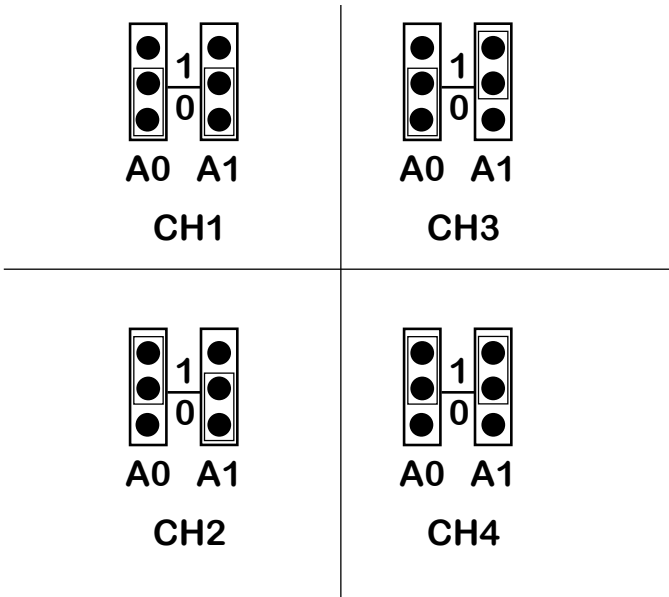

POWER SUPPLY AND BATTERY INSTALLATION

The Wireless Repeater requires 5VDC power to operate. Under the cover there is a two position terminal strip and battery clips for 3 AAA alkaline batteries. The batteries are used as a back-up in the event of an AC power failure. Connect the plug-in power supply to the power terminal block terminals. Be sure to connect the positive wire to the + terminal and the negative wire to the - terminal. After

the power supply is wired to the terminal strip plug it in, then install the batteries. See figure below:

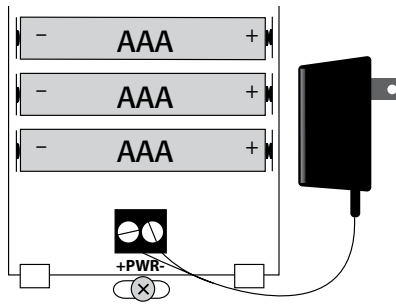

After you have configured the channel, plugged in the power supply and installed the AAA batteries, replace the cover and secure it by turning the two hex screws on the bottom of the cover counterclockwise.

BATTERY INFORMATION

The projected battery life is dependent upon many factors including: rated capacity of battery, state of charge, temperature, and sensor distance from the 2800 (or repeater). The farther a sensor is from its receiver the more power it will require to transmit its signal, thus reducing battery life. Higher temperatures will also decrease battery life. Always use high quality alkaline batteries in Sensaphone 2800 series wireless sensors. Remove the batteries from the sensor if you will be taking it out of service for a period of time.

NOTE: If the sensor has only batteries installed and it is not configured for communication with the 2800, it will consume maximum power trying to establish communication and result in premature battery failure.

COMMUNICATING WITH THE 2800

The sensor will communicate with the Sensaphone 2800 every 20 seconds. See chapter 4 for information on setting the wireless channel in the 2800. Once the repeater is powered up it will automatically start repeating data packets between the sensors and the 2800.

SPECIFICATIONS

Operating Temperature Range: 32° to 122° F (0° to 50° C)

Operating Humidity Range: 0- 95% RH non-condensing

Range (Indoor/Urban): Up to 300' (60m)

Range (Line-of-sight): Up to 4,000' (1,200m)

Transmit Power Output: 60mW (18dBm)

Operating Frequency: ISM 2.4 GHz

Power: 5VDC (300mA) plug-in adapter and (3) AAA alkaline batteries

Battery Life: Up to 15 hours

Dimensions: 4 1/2 " x 2 3/4" x 1 1/4"

Housing: White plastic

*Specifications subject to change without notice

APPENDIX A: Checking Your Sensaphone 2800 for Proper Operation

We recommend that you test your Sensaphone 2800 weekly to be sure it is functioning properly. This will ensure that when a problem arises the 2800 will be ready to alert the appropriate personnel. Sensaphone also recommends you keep a log of performed tests, and has provided you with a Test Log template at the back of this manual.

There are several tests that can be performed:

1. Call the unit and listen to the Status Report. This will test the unit's ability to answer the phone and speak a message. It will also verify that the inputs are reading properly, the alarm conditions are OK, the electricity is on, the microphone is functioning (optional), and that the battery is OK.
2. Create a test alarm on each input and allow the unit to contact all programmed telephone numbers. This will make sure that the 2800 is programmed properly. It will also prepare personnel to respond appropriately when they receive a call from the 2800. Listed below are suggestions on how to trip test alarms:
 - Temperature sensors: Heat or cool the sensor.
 - Motion sensors: Have someone walk in front of the sensor.
 - Door/window sensors: open the door/window.
 - Water sensors: Apply a small amount of water beneath the sensor or use a wet towel and touch it to the sensor probes.
 - Humidity sensors: Raise the humidity around the sensor by holding a cup of hot water beneath the sensor.
 - NO/NC Contacts: Open or close the contact.
 - Power sensor: Disconnect the power supply.

Allow the unit to contact all programmed telephone numbers. This will make sure that the 2800 is programmed properly. It will also prepare personnel to respond appropriately when they receive a call from the 2800.

3. Test the battery by unplugging the AC adapter and making sure that the 2800 continues to function. Check that the BATTERY OK LED remains on steady. Press WHAT IS, then STATUS on the keypad, and listen to the status report. Make sure the report states that “power is off” and “battery is OK.” Keep the AC adapter unplugged so that a Power Failure alarm occurs. Allow the unit to dial all programmed telephone numbers while running on battery backup. Plug in the AC adapter after the unit has finished dialing all of the telephone numbers.

APPENDIX B: Replacing the Back-up Battery

The back-up battery will provide about 3–5 years of service life depending on usage and temperature. After 5 years (or when back-up time is insufficient) the battery should be replaced. Replacement batteries can be ordered from Sensaphone (*Part number BAT-0006*). To replace the battery, follow the instructions below:

WARNING: When removing and replacing the battery, be careful not to short out the battery terminals on the bracket or back panel. A large spark and/or battery damage could result.

1. Turn the power switch off and unplug the power transformer.
2. Loosen the compression wiring connectors and allow 6-10" of cable slack to come into the enclosure. This will make it easier to turn the panel over.
3. Remove the four corner screws securing the keypad/pcb panel and turn the panel over.
4. Remove the connectors from the battery by carefully pulling and wiggling the connectors from the battery tabs.
5. Remove the screws holding the battery bracket and remove the bracket.
6. Dispose/Recycle the old battery following local disposal regulations for lead batteries.
7. Attach the battery connector at the end of the BLACK wire to the -(negative) terminal of the new battery.
8. Attach the battery connector at the end of the RED wire to the +(positive) terminal of the new battery.
9. Insert the new replacement battery into the slot and replace the bracket. Secure the bracket with the two screws.
10. Place the main panel over the four metal stand-offs and reattach the four corner screws.

11. Readjust the cables through the compression connectors and secure the fittings.
12. Plug the power transformer into the outlet and turn on the power switch.

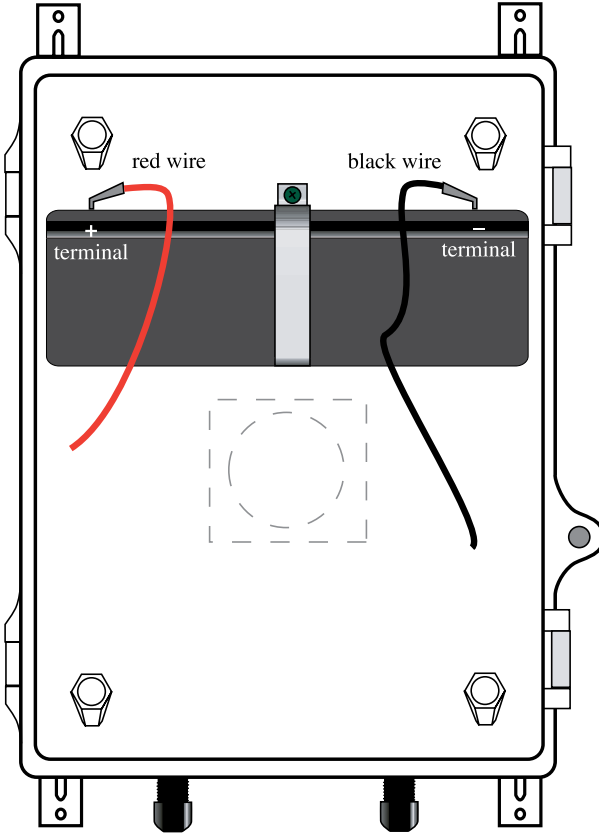

Figure 1: Back-up Battery placement

APPENDIX C: Troubleshooting the 2800

In the event that a problem is encountered, this section will assist you in determining the cause so you can return the unit to its normal monitoring routine with minimal interruption.

Most problems with the 2800 are easy to identify and quickly corrected. See the information under the following general headings:

- Communications/Dialout functions
- Temperature monitoring
- 4–20mA monitoring
- Sound level monitoring
- Other monitoring functions

If you have tried the solutions outlined in this section and are not satisfied with the results, call Sensaphone Technical Support toll-free at 1-877-373-2700. If it is determined that your 2800 requires repair please follow the instructions in Appendix H for returning your unit for service.

COMMUNICATIONS/DIAL-OUT:

Problem 1

The 2800 fails to dial out.

Cause

- a) The telephone number may be incorrectly programmed.

- b) Tone or pulse (the current dialing method) is not compatible with the telephone line on which the 2800 is installed.

- c) Recognition Time is too long. An alert condition does not remain in effect long enough to become a valid alarm.

- d) Max Calls is set to zero.

- e) The 2800 is connected to an incompatible telephone line.

Solution

- Recheck programming steps and use the dial-out test mode to listen to the unit dial. Refer to Chapter 5.

- Switch from the current setting: from tone to pulse, or from pulse to tone. Refer to Chapter 5.

- Reprogram Recognition Time. Set the Recognition Time to the minimum duration required to create a valid alarm. If possible, test the new setting by deliberately creating an alert condition. Refer to Chapter 4.

- Reprogram Max Calls. It is a good idea to set your Max Calls to at least equal the number of dial-out telephone numbers programmed. Refer to Chapter 5.

- The 2800 must be connected to a standard (2-wire analog) telephone line, not a digital extension to a phone system. If the unit will not dial out and the factors previously listed have been ruled out, try connecting the unit to a standard residential telephone line.

Problem 2

The 2800 will not answer the telephone when called for a Status Report or alarm acknowledgment.

Cause

- a) Rings Until Answer is incorrectly programmed.
- b) The 2800 is connected to an incompatible telephone line.

Solution

Recheck programming of Rings Until Answer. Refer to Chapter 5.

Some telephone systems will not allow the telephone to ring beyond 4 rings. If your 2800's Rings Until Answer is set at more than 4 rings, you may not be able to access the unit. Try setting the Rings Until Answer to less than 4 rings. If this does not correct the problem, it may indicate telephone line incompatibility. In this case, try connecting the 2800 to a standard, residential telephone line.

Problem 3

The 2800 will not answer the telephone for Callback Acknowledgment.

Cause

You did not allow the telephone to ring 10 times. Note: If the TAD (telephone answering device) is disabled, the telephone rings ten times before the 2800 answers. If the TAD is enabled, you must call and let the line ring once; hang up and call back again within 30 seconds. The 2800 will answer on the first ring and acknowledge the alarm.

Solution

When calling the 2800, and the TAD is disabled, allow the telephone to ring 10 times. Refer to Chapter 5.

COMMUNICATIONS/DIAL-OUT *(continued)*

Problem 4

The 2800 recites the alarm message or Status Report over the telephone, but is silent at the installation sight.

Cause

The local voice mute feature is in effect.

Solution

Deactivate local voice mute. Refer to the programming steps in Chapter 5.

Problem 5

The 2800 and telephone answering device (sharing the same line) answer incoming calls simultaneously.

Cause

The 2800's number of Rings Until Answer is set to equal the number of rings set for the telephone answering device.

Solution

Change the number of Rings Until Answer for the 2800.
Refer to Chapter 5.

TEMPERATURE MONITORING:

Problem 1

Can't program temperature limits; or the unit won't read the temperature sensor.

Cause

The zone isn't configured to read a temperature sensor.

Solution

Press SET and CONFIGURE to program the zone. For 10K thermistor, you must manually configure. See Chapter 4.

Problem 2

The temperature reading is -121° F or -85° C [2.8K];
or -87° F or -85° C [10K].

Cause

The temperature sensor has been disconnected or has broken wires.

Solution

Examine the wires to temperature sensor and connect or replace wiring.

Problem 3

The temperature reading is 115° F or 57° C [2.8K];
or 168° F or 76° C [10K].

Cause

Temperature sensor wires are touching or have shorted.

Solution

Verify and correct wiring.

TEMPERATURE MONITORING *(continued)*

Problem 4

Temperature reading is inaccurate.

Cause

- a) The zone is configured for the wrong type of thermistor (i.e., 2.8k vs. 10k)
- b) Temperature sensing may be affected by a source of ambient heat (ie., direct sunlight, or heat duct proximity).
- c) Temperature may require calibration.
- d) The unit is using the wrong temperature scale (Fahrenheit vs. Celsius).

Solution

- Manually configure the zone as described in Chapter 4.
 - Try moving the sensor to a different location.
 - After moving or placing the sensor away from ambient heat sources, the temperature may be calibrated to offset inaccurate normal reading by several degrees.
Refer to Chapter 4.
 - Verify temperature scale.
Refer to Chapter 4.
-

4–20mA MONITORING:

Problem 1

Can't program 4–20mA range; or the unit won't read the 4–20mA sensor.

Cause

The zone isn't configured to read a 4–20mA sensor.

Solution

Press SET and CONFIGURE to program the zone. See Chapter 4 for information on zone configuration.

Problem 2

The zone input is not reading correctly.

Cause

- a) No power connected to the transducer.
- b) Incorrect wiring.
- c) The table range is incorrectly programmed.
- d) The input is not configured for 4–20mA.
- e) Multiple devices connected in loop.

Solution

- Connect a power supply as shown in Chapter 2.
 - Inspect wiring. Make sure polarity is correct as shown in Chapter 2.
 - Program the table range for the calibrated range of the transducer.
 - Configure the zone for 4–20mA. Refer to Chapter 4.
 - The 2800's zone is single-ended and terminates to ground. Because of this, the 2800 must be the last device in the loop, and in some cases the ONLY device. For certain installations, it may be necessary to use a signal isolator.
-

SOUND LEVEL MONITORING:

Problem 1

False high sound alarms occur frequently.

Cause

a) The programmed sound sensitivity results in over-sensitivity to non-alarm sound as well as alarm sound.

b) Sound Recognition Time is too short.

Solution

Reprogram the sound sensitivity (calibration). Refer to Chapter 4.

Lengthen the sound Recognition Time. Refer to Chapter 4.

Problem 2

High sound does not cause an alarm.

Cause

a) The microphone is not close enough to the high sound source, or the programmed sound setting results in a lack of sensitivity to high sound.

b) No remote microphone (optional) connected to the unit.

Solution

Move the microphone closer or reprogram the sound sensitivity. Refer to Chapter 4.

Connect a remote microphone to the Mic terminals.

OTHER MONITORING:**Problem 1**

Alarm status of a zone is incorrect.

Cause

Incorrect zone configuration.

Solution

Reconfigure the zone. See Chapter 4.

Problem 2

False power-out alarms.

Cause

Programmed Recognition Time is too short.

Solution

AC power may be subject to brief interruptions. To avoid frequent, false alarms, increase the power Recognition Time. Refer to Chapter 4.

Problem 3

The 2800 does not recognize power failure.

Cause

- a) Battery is either incorrectly installed or drained.
- b) Recognition time setting is too long.

Solution

To verify proper battery function, unplug the unit and verify continued operation using battery only. If unit ceases to function, replace the battery. Refer to Appendix B.

Reprogram Recognition Time. Set the Recognition Time to the minimum required before a valid alarm occurs. If possible, test the condition by deliberately creating an alert condition. Refer to Chapter 4.

OTHER MONITORING (continued)

Problem 4

The 2800 does not recognize any alarm.

Cause	Solution
a) Zones for alarm are disabled.	Enable the zones for alarm. See Chapter 4.
b) Programmed Recognition Time is too long.	Reprogram Recognition Time. Set the Recognition Time to the minimum required for a monitored condition to become a valid alarm. If possible, test the condition by deliberately creating an alert condition. Refer to Chapter 4.

Problem 5

The batteries drain prematurely.

Cause	Solution
The unit's AC transformer is unplugged or for some other reason full AC power is not available to the unit.	The batteries will take over powering the unit when the AC transformer is unplugged from the 120 VAC outlet. When storing the unit, be sure to turn the power switch off.

If the solutions offered above do not appear to correct the problem, apply the following steps, in the order shown.

- Turn the power switch off.
- Wait one minute for the 2800 to completely power down.
- Turn the power switch on.
- Reconfigure the zones. Refer to Chapter 4.

Refer to Chapter 2, Installation, for additional information on batteries and installation procedures. Contact Sensaphone Technical Support toll-free at 1-877-373-2700.

Problem 6

Zone status is not being recited in the status report.

Cause

The zone has probably been designated as unused.

Solution

See Chapter 4 (p55)

WIRELESS SENSORS:

Problem 1

The 2800 won't add my wireless sensor or the 2800 has frequent wireless communication alarms.

Cause

There are several possibilities:

- a) The sensor may be too far from the 2800
- b) The sensor may not be receiving power.
- c) There may be interference from another 2.4GHz device.
- d) Sensor antenna may be poorly positioned relative to the 2800.

Solution

- a) Move the sensor or the 2800 so that they are closer to each other
 - b) Add a repeater between the 2800 and sensor.
 - c) Change to a different wireless channel on both the 2800 and all of your sensors.
 - d) Increase the distance from other 2.4Ghz devices such as wireless routers or laptop computers with wireless capability.
 - e) Make sure the power supply wires are connected correctly.
 - f) Check that the batteries are installed correctly.
 - g) Adjust the sensor antenna or reposition the sensor.
-

Problem 2

There is a delay from the time the alarm occurs until the 2800 responds

Cause

- a) The sensors only communicate with the 2800 once every 20 seconds so a delayed response to an alarm is normal.

APPENDIX D: 2.8 and 10K Thermistor Tables

2.8K Thermistor Data

Degrees Celsius	Resistance (Ohms)
-50	187,625
-40	94,206
-30	49,549
-20	27,180
-10	15,491
0	9,142
10	5,572
20	3,498
30	2,256
40	1,491
50	1,009
60	697
70	490
80	351

10K Thermistor Data

Degrees Celsius	Resistance (Ohms)
-30	135.2K
-20	78.91K
-10	47.54
0	29.49K
10	18.79K
20	12.25K
30	8,194
40	5,592
50	3,893
60	2,760
70	1,990

APPENDIX E: 2800 Technical Specifications

Hard-Wired Environmental Inputs

Number of Zones: 4

Zone Connector: terminal block

Zone Types: N.O./N.C. contact, 2.8K (-109° to 115° F; -85° to 57° C), and 10K thermistor (-87° to 168° F; -66° to 76° C), and 4–20mA (-10,000 to 10,000)

Zone characteristics: 28K Ω to 2.85V (temperature/contact) or 250 Ohms to ground (4–20mA)

A/D Converter Resolution: 10 bits \pm 2 LSB

Zone Protection: Metal oxide varistors, and fast-acting diode clamps

Wireless Environmental Inputs

Number of Sensors: 4

Operating Frequency: ISM 2.4 GHz

Receiver Sensitivity: -100dBm

Transmit Power Output: 60mW

Microphone

Internal: for recording custom voice messages

External (optional): For listening in to on-site sounds and high sound level alarms

- Mic Connector: terminal block
- Mic Type: Electret Condenser
- Mic Impedance: 2.2K Ω

Phone Interface

Terminals for connection to a two-wire analog telephone line

Line seizure terminals for connecting extension telephone devices

LED Indicators: (4) Hard-Wired Zone Alarms, (4) Wireless Zone Alarms, Sound, Power, Battery OK, Phone in Use, Output On, and System On

Relay Output: 2A 120VAC/2A 24VDC—Programmable for automatic or manual switching

Power Supply

Power Supply: 120VAC/9VDC 60Hz 10W wall plug-in transformer

Power Consumption: 5 Watts

Power Protection: Metal Oxide Varistor

Battery Backup: 6V 3.4 AH sealed gel cell, provides up to 16 hours of back-up time

Environmental

Operating Temperature: 32–122 deg F (0–50 deg C)

Operating Humidity: 0–90% RH non-condensing

Storage Temperature: 32–140 deg F

Physical

Dimensions: 12.1"h x 7.3"w x 4.5"d

Weight: 5 lbs.

Enclosures:

- Solid Door Enclosure: ABS Plastic, UL94V-0 Flammability rating, NEMA Type 1, 2, 3, 3R, 4, 4X, 12 & 13, IEC529, IP66.
- Clear Door Enclosure: ABS/PC blended plastic, UL94-5VB

flammability rating; [Clear Door] Polycarbonate plastic, UL94V-0 flammability rating. UV stabilized NEMA Type 1, 2, 3, 3R, 4, 4X, 12 &13, IEC529, IP66.

Specifications subject to change without notice

APPENDIX F: 2800 Quick Reference Guide

Communications

ID Number	Identification number of the 2800 [SET] or [WHAT IS] + [ID/POWER] Range=0–16 digits, Default=blank
ID Message	Custom message identifying the 2800 [SET] or [WHAT IS] + [MESSAGE] + [ID/POWER] Max: 5.3 seconds Default=N/A
Zone Message	Message identifying the zone in alarm [SET] or [WHAT IS] + [MESSAGE] + [zone #] Max: 4.6 seconds Default=N/A
Voice Repetitions	Number of times alarm message is repeated over the phone [SET] or [WHAT IS] + [VOICE REPS] Min: 1 reps, Max: 10 reps Default=3 reps
Dial-Out Phone Numbers	Phone numbers dialed to report alarm conditions [SET] or [WHAT IS] + [PHONE NUMBER] + [number 1–8] Max: 8 numbers, 48 digits each Default=N/A
Call Delay	Time delay until first call is made [SET] or [WHAT IS] + [CALL DELAY] (min:sec) Min: 00:00 Max: 60:00 Default=00:30
Intercall Time	Time delay between phone calls [SET] or [WHAT IS] + [INTERCALL TIME](min:sec) Min: 00:10, Max: 60:00 Default=00:30
Max Calls	Number of calls until unit self-acknowledges [SET] or [WHAT IS] + [MAX CALLS] Min: 1 calls, Max: 255 calls Default=100 calls
(TAD) Answering Device Compatibility	Allows 2800 to bypass answering devices on the same line [SENSOR ON/OFF] + [RINGS/TAD/*] On or Off, Default=Off
Rings Until Answer	Number of rings until unit answers an incoming call [SET] or [WHAT IS] + [RINGS/TAD/*] Min: 1 ring, Max: 15 rings DEFAULT=4 rings
Speaker Mute	Turns off the speaker during alarm conditions [SENSOR ON/OFF] + [HISTORY/MUTE] On or Off Default=Off
Call Progress	Disables call progress detection feature [SENSOR ON/OFF] + [STATUS/CONFIGURE] Enabled or Disabled Default=Enabled

Callback Acknowledgment Allows alarm acknowledgment with 10 rings
[SENSOR ON/OFF] + [CODE]
On or Off Default=Disabled (*off*)

Tone or Pulse Dialing Dialing method—touch-tone or pulse
[SENSOR ON/OFF] + [PHONE NUMBER T/P]
Tone or Pulse Default=Tone

Alarm Programming

Temp Alarm Limits High and low temperature alarm limits
[SET] or [WHAT IS] + [LOW LIMIT] or [HIGH LIMIT]+[zone #]
Min: -109°F/-65°C Max:168°F/76°C Default=Low: 0°F; High:100°F

4–20mA Table Range Defines upper and lower range of 4–20mA sensor
[SET] or [WHAT IS] + [TABLE RANGE] + [zone #]
Min: -10,000, Max: 10,000 Default=Low: 0, High:100

4–20mA Alarm Limits High and low alarm limits
[SET] or [WHAT IS] + [LOW LIMIT] or [HIGH LIMIT] + [zone #]
Min: -10,000, Max: 10,000 Default=Low: 0, High: 100

Zone Calibrate Offset correction factor [temp/4-20mA]
[SET] or [WHAT IS] + [CALIBRATE] + [zone #]
Min: -1.5°/-100, Max: 1.5°/100 Default=0

Auto. Zone Configuration Automatically configures all zones.
[SET] + [STATUS/CONFIGURE] + 0
Default=n/a

Manual Zone Configuration To configure an individual zone type (*required* for 10K Temp)
[SET] + [STATUS/CONFIGURE] + [zone #] + [type]
1 = NO, 2 = NC, 3 = 2.8K Temp, 4 = 10K 5 = 4–20mA
Default=n/a

Recognition Time Zones 1–8 Length of time a fault condition must exist to trip an alarm
[SET] or [WHAT IS] + [REC TIME] + [zone #]
Min:00:00, Max: 540:00 Default=00:03 (min:sec)

Rec Time: Power Failure Length of time the power must be off to trip an alarm
[SET] or [WHAT IS] + [REC TIME] + [POWER]
Min: 00:00, Max: 540:00 Default=05:00 (min:sec)

Rec Time: High Sound Level Length of time the sound must be high to trip an alarm
[SET] or [WHAT IS] + [REC TIME] + [SOUND]
Min: 00:05, Max: 00:60 Default=00:08 (min:sec)

Sound Level Alarm Sensitivity Microphone sensitivity for high noise level alarm
[SET] or [WHAT IS] + [CALIBRATE] + [SOUND]
Min: 1 (most), Max: 160 (least) Default=32

Enable/Disable Zone Turns zone alarm detection on or off
[SENSOR ON/OFF] + [zone #]
On or Off Default=Enabled (*on*)

- Power Alarm Enable/Disable** Turns power alarm detection on or off
[SENSOR ON/OFF] + [POWER]
On or Off Default=Enabled (on)
- Sound Alarm Enable/Disable** Turns high sound level alarm detection on or off
[SENSOR ON/OFF] + [SOUND]
On or Off Default=Enabled (on)
- Temperature Scale** Selects between Fahrenheit and Celsius
[SENSOR ON/OFF] + [TEST/°F/°C]
Fahrenheit or Celsius Default=Fahrenheit
- Temperature-Only Status Report** A limited status report that only includes inputs configured as temperature.
[WHAT IS] + [TEST/°F/°C]
- Designating a Zone Unused or Deleting a Wireless Sensor** Removes zone from status and alarm reports
[SENSOR ON/OFF] + [SET] + [zone #]
On or Off Default=on

Special Functions

- Dial-Out Test Mode** Simulates alarm to test telephone programming
[SET] + [TEST] + [# key 1-8]
Default=none
- Listen-In Time** Length of listen-in time during call-in status report
[SET] or [WHAT IS] + [LISTEN TIME]
Min: 0 sec, Max: 255 sec Default=00:00 (min:sec)
- Acknowledgment Code** To create an individual user's 4-digit acknowledgment code
[SET] + [CODE] + [# key 1-8] + [4 digit code]
Default=555 for single-user mode
- Date & Time** Internal clock/calendar
[SET] or [WHAT IS] + [DATE/TIME/#]
Date: mmddyy, Time: hhmm Default=none
- Alarm History** Recites last 10 alarms
[WHAT IS] + [HISTORY]
Default=n/a
- Reset History** Clears the alarm history
[SET] + [HISTORY]
Default=n/a
- Switch Output** Turns output relay on or off (in manual mode)
[SENSOR ON/OFF] + [OUTPUT]
On or Off Default=off
- Output Mode** Program relay output as manual or automatic for specific zone
[SET] or [WHAT IS] + [OUTPUT] + [mode number]
Default>manual mode

Remote Security

Prohibits programming changes via telephone
[SET] or [WHAT IS] + [ENTER/LOCK] + [4 digit code]
Default=unlocked

Press [ENTER] after all Key Sequences starting with [SET].
Use [SET] to establish parameters, [WHAT IS] to verify them.

SPECIAL KEY FUNCTIONS

RING/TAD/*

Used to enter a minus sign for negative alarm limits or calibrations.

DIALOUT CODES

- CODE 1 Numeric pager call type
- CODE 2 Inserts a “Wait for answer”
- CODE 3 Change to Touch-Tone dialing

APPENDIX G: Accessories

The sensors and accessories listed below are available from Sensaphone, and represent the most commonly used devices. Other dry contact sensors or 4–20mA transducers, designed for more specialized applications, may also be used. Commercial or industrial electrical supply houses can provide devices to monitor virtually any condition. For further information, contact a Sensaphone Sales Associate toll-free at 1-877-373-2700.

<u>PART</u> <u>NUMBER</u>	<u>WIRELESS</u> <u>SENSORS</u>
------------------------------	-----------------------------------

WSR-0100	Wireless Indoor Temperature Sensor
WSR-0101	Wireless Indoor Dry Contact Sensor
WSR-0102	Wireless Indoor Power Failure Sensor
WSR-0103	Wireless Indoor Humidity Sensor
WSR-0104	Wireless Indoor 4-20mA Sensor
WSR-0105	Wireless Indoor Motion Detector
WSR-0106	Wireless Indoor Spot Water Detection Sensor
WSR-0107	Wireless Indoor Zone Water Detection Sensor
WSR-0199	Wireless Indoor Repeater

<u>PART</u> <u>NUMBER</u>	<u>WIRED</u> <u>SENSORS AND ACCESSORIES</u>
------------------------------	--

FGD-0006	Magnetic Reed Switch
FGD-0007	Passive Infra-Red Detector
FGD-0010	50' two-conductor #22AWG shielded accessory Cable
FGD-0013	Spot Water Detector
FGD-0022	Temp° Alert
FGD-0027	Humidistat
FGD-0049	Smoke Detector with Built-in Relay

FGD-0052	Humidity Transmitter
FGD-0053	24VDC Power Supply
FGD-0054	Power-Out Alert™
FGD-0056	Zone Water Detector w/Water Rope
FGD-0057	External Microphone
FGD-0060	Line Seizure Kit
FGD-0063	10' additional Water Rope for FGD-0056 or WSR-0107
FGD-0064	Surge Suppressor
FGD-0100	2.8K Remote Temperature Sensor
FGD-0101	2.8K Weatherproof Temperature Probe
FGD-0102	10K Weatherproof Temperature Probe
FGD-2810	Outdoor Weatherproof Antenna Kit

APPENDIX H: Returning Your 2800 for Repair

In the event that the 2800 does not function properly, we suggest that you do the following:

1. Record your observations regarding the 2800's malfunction.
2. Call Sensaphone Technical Support toll-free at 1-877-373-2700 or e-mail support@sensaphone.com prior to sending the unit to Sensaphone for repair. Our product support specialists are able to diagnose and correct many unit setup and programming problems over the phone.

If the unit must be sent to Sensaphone, Inc. for Servicing, please do the following:

1. Turn the power switch Off, disconnect all wiring and unplug the unit.
2. Carefully pack the unit to avoid damage in transit. Use the original container (if available) or a sturdy shipping box.
3. To avoid shipping delays, you must include the following information:
 - a) Your name, address and telephone number.
 - b) A note explaining the problem.

A convenient form is available for sending your unit in for repair. Just go to www.sensaphone.com and click *Support*, then *Repair Services*.

4. Ship your package to the address below:

SERVICE DEPARTMENT
Sensaphone
901 Tryens Road
Aston, PA 19014

5. Ship prepaid and insured via UPS or US Mail to ensure a traceable shipment with recourse for damage or replacement.

2800 Index

Symbols

2800

- Accessories 173
- Features 18
- Layout 19
- LED Indicators 30–31
- Operating Environment 21–23
 - Grounding 22
 - Locking the Enclosure 22
 - Mounting the 2800 21
 - Wiring Connectors 23
- Operation 96–105, 106–115
 - Alarm Acknowledgment
 - Automatic (Max Calls) 100
 - Numeric Pager Dialout 99
 - Voice Dialout 98
 - Alarm Dialout and Acknowledgment 96–97
 - Alarm Dialout-Pager 97
 - Alarm Dialout-Voice 96–97
 - Alarm Notification 96
 - Alarm Recognition 96
 - Dialout Note: Call Progress 96
 - Call-In Status 100
 - Remote Commands via Touch-Tone Phone 101–104
- Returning for Repair 175
- Technical Specifications 166–168
- Telephone Line 25
 - Line Seizure 25
- Troubleshooting 153–162
- Turning the 2800 On 24–25
 - Backup Battery 24–25
- Wiring Sensors and Transducers 26–28
 - Wiring Recommendations 29

B

- Back-up Battery
 - Replacing 151–152

C

- Communication Programming 58–91
 - Alarm Acknowledgment Codes 74–76
 - Alarm Dial-out Telephone Numbers 65–70
 - Numeric Pager Dialout 67–70
 - Voice Dialout 65–66
 - Alarm History 76
 - Callback Acknowledgment 90–91
 - Call Delay Time 78–79
 - Call Progress 83
 - Date and Time 59
 - Dial-Out Test Mode 72–73
 - ID Number 63–64
 - Intercall Time 81–82
 - Listen-In Time 86
 - Max Calls 84–85
 - Remote Programming Security Code 88–89
 - Speaker Mute 90
 - Special Dialing Options 71–74
 - Change to Touch-Tone Dialing 72
 - Special Dialing Code Summary 72, 103
 - TAD Compatibility 86
 - Tone or Pulse Dialing 77
 - Voice Messages 60–63
 - Voice Repetitions 83

L

- LED Indicators 30–31

O

- Operation
 - Testing 149–150
- Output Control 92–95
 - Automatic Modes 92–93
 - Manual Mode 93–95

Q

- Quick Reference Guide 169–172
- Quick Start Guide
 - Aborting a Command 32
 - Acknowledging a False Alarm 33
 - Error Messages 32–33
 - How the Keypad Commands Work 32
 - Recommended Programming Steps 33

T

- Technical Support 20
- Test Log 181–182
- Thermistor Tables
 - 10K 165
 - 2.8K 164

W

- Wiring Sensors and Transducers 26–28

Z

- Zone Programming 34–55
 - Alarm Limits 49–51
 - Alarm Recognition Time 46–48
 - Calibration 52–53
 - Configure Range for 4-20mA sensors 44–45
 - Configure Temperature Scale 43
 - Designating a Zone as Unused 55
 - Enable/Disable Power 42–43
 - Enable/Disable Sound Level Alarm 42
 - Enable/Disable Zone Alarms 41–42
 - Exit Delay 56
 - Sound Level Calibration 53–54
 - Temperature-Only Status Report 57

